



METAL MOUNTINGS VIBRACHOC RANGE

PAULSTRA



HUTCHINSON[®]
WORLDWIDE



METAL MOUNTINGS VIBRACHOC RANGE

CONTENTS

	Page
I - STEEL MOUNTINGS	3
II - VIBRATION AND SHOCK GENERAL	4
III - APPLICATIONS	9
IV - INDUSTRIAL APPLICATIONS	
IV.1 Machine tools and impact machinery	10
IV.2 Rotating and vibrating machines	11
IV.3 Vehicles	12
IV.4 Offshore machinery	13
IV.5 Construction	14
V - SELECTION GUIDE	16
VI - APPLICATIONS GUIDE	18
VII - DATA SHEETS	
• METAL CUSHIONS	20
• VIBSOL	24
• VI786-A06, VI700-A06, VI700-B06	26
• METAL CUSHIONS FOR PIPES	29
• V43, V44, V45, V46	31
• V47, V47D, V47T, V47Q	34
• PDM-1000-01, PDM-2000-02	36
• SP550W to SP563W	37
• SP539-882 to SP539-888	38
• V118-MG, V118-DG, V318, V318-D	40
• V120, V120-D, V125, V125-D	42
• V164, V168	44
• V402-MG	46
• V1H751, V1H752	48
• V1H5023, V1H5025	50
• V1H-6000, V1H-6100	52
• V1B1114 to V1B1136	54
• 7002	57
• VE101, VE111, VE112, VE113	59
• VIBCABLE	61
• OTHER METAL CUSHIONS	
- MV801, MV803	64
- V1N303, V1N304, V1N305, V1N306, V1N308	65
- V1209	66
- V1210	67
- V1B-5984-01, V1B-5984-11	68
VIII - NUMERIC INDEX	69

See current price list for availability of items.
We reserve the right to modify the design and manufacture of the products and materials described in this catalogue.

The pictures of the products are supplied for information only.

The order comprises:

- the contract signed by both parties, or the purchase order and the acknowledgement of receipt,
- eventually, special or specific additional conditions,
- sale general conditions, available upon request are part of the order.

METAL MOUNTINGS VIBRACHOC RANGE

I - STEEL MOUNTINGS

VIBRACHOC have a range of all steel mountings whose essential element is the “**steel cushion**” made from woven stainless steel wire and compressed.

Steel mountings have considerable mechanical strength as well as high damping characteristics in the order of 10 to 20%, depending on the application.

ADVANTAGES

Stability. Steel mountings provide stable characteristics and the height under load remains constant with time.

Unaffected by corrosion. Steel dampers are unaffected by oil, grease, solvents, adverse weather and corrosive products.

Unaffected by temperature. Steel dampers withstand temperatures from - 70°C to + 300°C without changing characteristics.

Low natural frequency. Steel mountings with springs can have natural frequencies as low as 3 Hz, which can provide up to 98% attenuation for low speed rotating machinery.

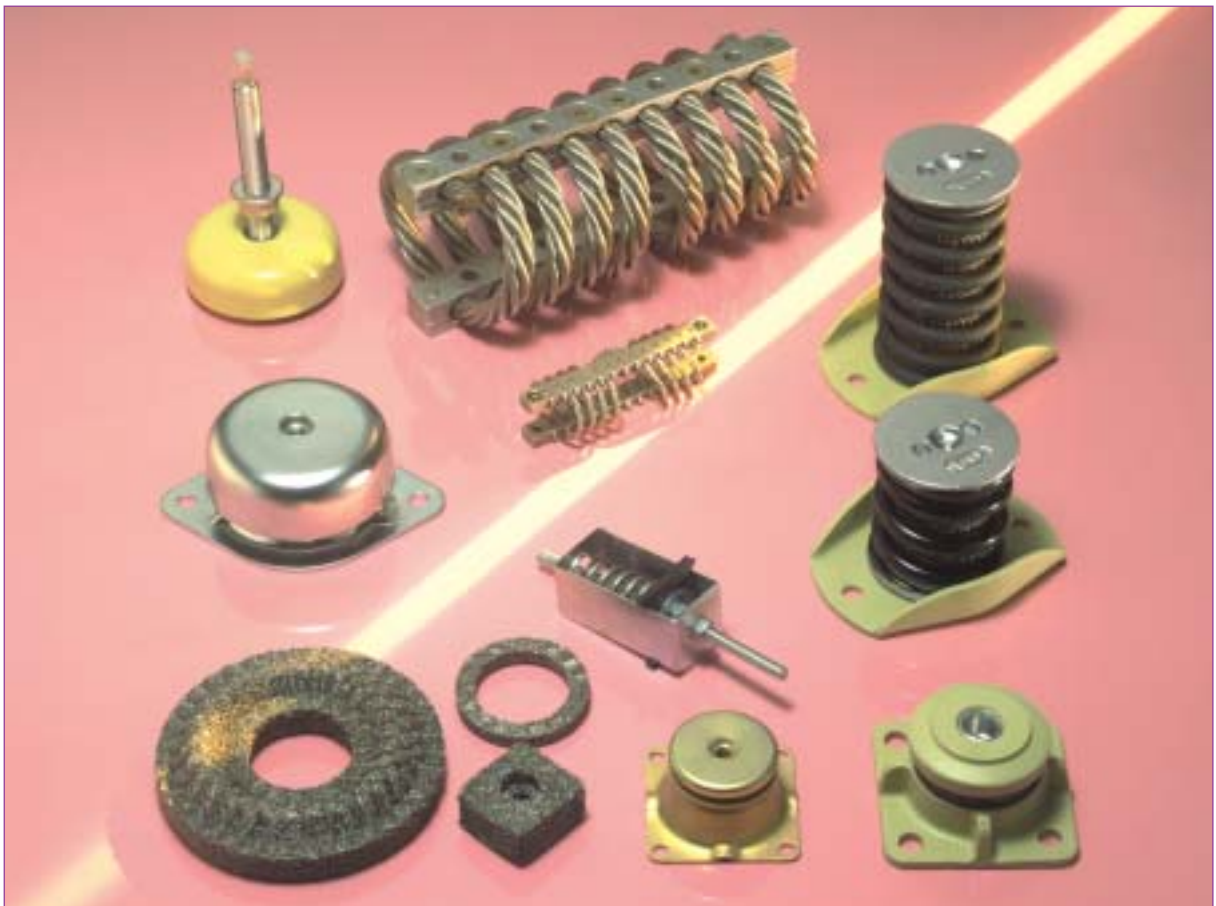

II - GENERAL INFORMATION ON VIBRATIONS AND SHOCK

PURPOSE OF AN ELASTIC SUSPENSION

An appropriate elastic mounting placed between the support and the equipment usually fulfils two functions:

- It has an important static role: it provides better load distribution by absorbing certain manufacturing tolerances, thus allowing more reliable, cheaper installation.
- It has a dynamic role: it provides protection against vibration and shock, considerably reducing the surrounding vibration and increasing the life time of the equipment isolated.

THEORY

Natural frequency

An elastic mounting is characterised by its load-deflection curve. The load produced by a mass M causes a static deflection δ (difference between the unloaded height and the height under load) and a subtangent Δ .

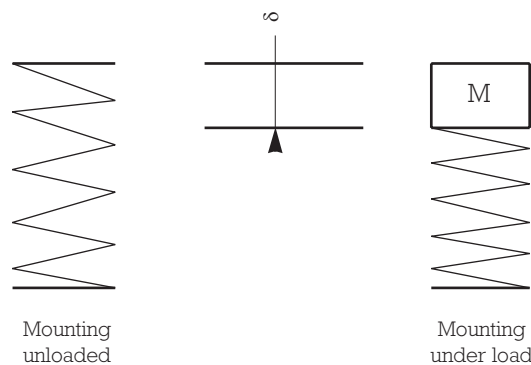

The Natural frequency of the suspended mass is given by the formulae

$$f \text{ in Hz } f = \frac{1}{2\pi} \sqrt{\frac{K}{M}}$$

K = stiffness of the mounting in N/m

$$M \text{ in kg } f = \frac{15.8}{\sqrt{\delta}}$$

Δ = dynamic deflection in mm

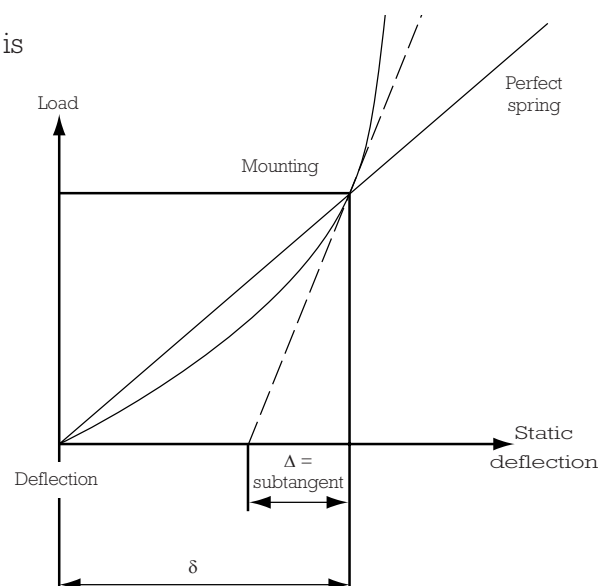

The load-deflection curve is linear for a theoretical spring but is not necessarily linear for a mounting. The form of the curve is highly variable and depends on the design and materials of the mountings.

Natural frequency

The purpose of a mounting is to reduce the transmission of excitation forces between the suspended mass and the foundation. The degree of attenuation obtained depends firstly on the natural frequency of the mounting or, more exactly, on the ratio of f_e (excitation frequency) to f_n (natural frequency).

In the simplest case, that of a single degree of freedom (vertical translation), the natural frequency of the mass + isolator without damping and is written:

$$f_n = \frac{1}{2\pi} \sqrt{\frac{K}{M}}$$

$$f_n = \text{Hz}$$

K = Stiffness of isolator in N.m

M = Kg

Model of an elastic mount

K = stiffness

ε = damping

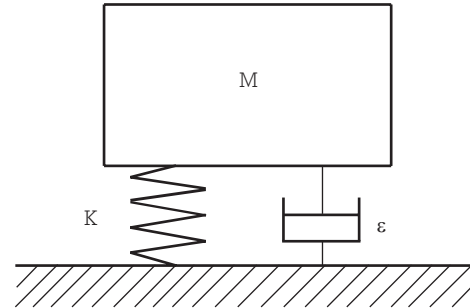

Transmissibility is the ratio of the transmitted force f_r to the excitation force f_e . Examination of the curve opposite shows that:

- for $f_e/f_n < \sqrt{2}$ and in particular when the natural frequency of the mounting is greater than the excitation frequency, there is amplification of vibration rather than attenuation.

This illustrates the fact that the selection of unsuitable resilient mounting makes the problem worse rather than solving it.

- for $f_e/f_n > \sqrt{2}$, the excitation is attenuated. This shows the advantages of using a mounting with a natural frequency (f_n) as low as possible in relation to the excitation frequency (f_e). The greater the difference, the higher the degree of attenuation.

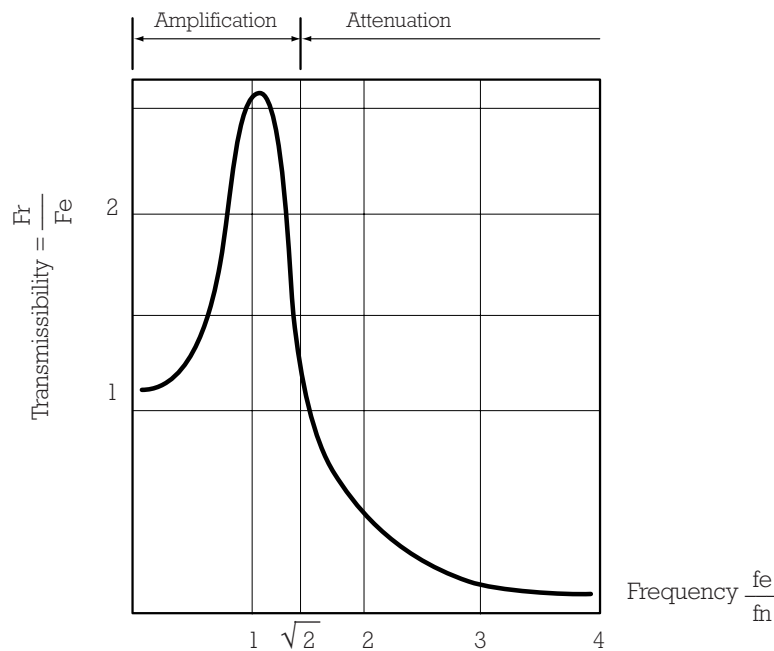

Damping

Damping dissipates vibrational energy by dry or viscous friction and acts as a brake, preventing displacement of the suspended assembly.

It can be seen that:

- for $f_e/f_n < \sqrt{2}$, the amplification decreases with higher damping, particularly when close to resonance.

- for $\omega/\omega_0 > \sqrt{2}$, attenuation improves with lower damping.

To limit amplification at resonance while achieving good attenuation, it is necessary to find a good compromise when choosing a damper.

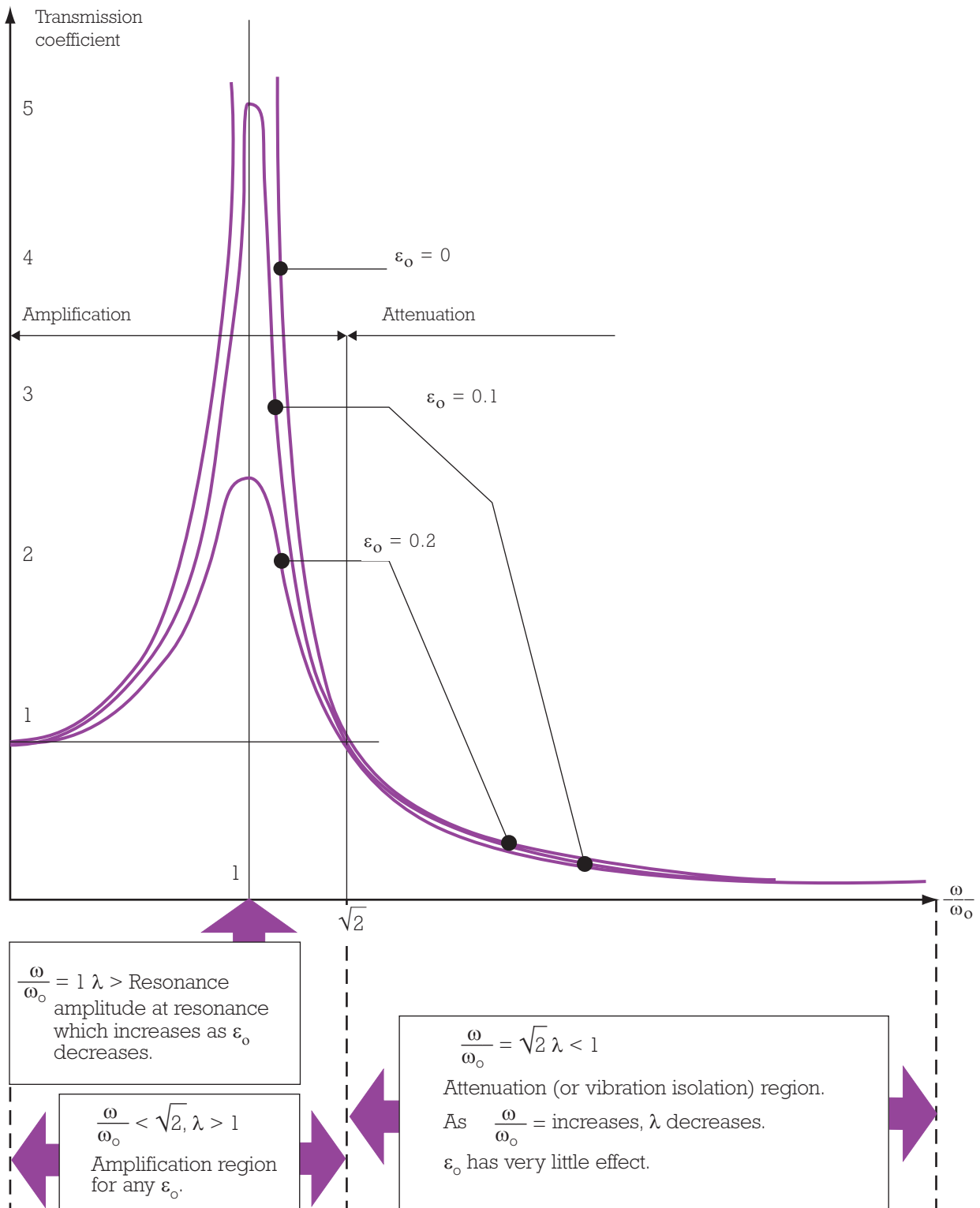

For an efficient mounting system use:

- a high value of $\frac{\omega}{\omega_0}$ \longrightarrow low value of ω_0 \longrightarrow low value of λ
- a high value of ϵ_0 \longrightarrow - limited amplification in the resonant region
- minor effect in the attenuation region

**Attenuation as a function of natural frequency and frequency of excitation
(A theoretical graph for a mounting system without damping)**

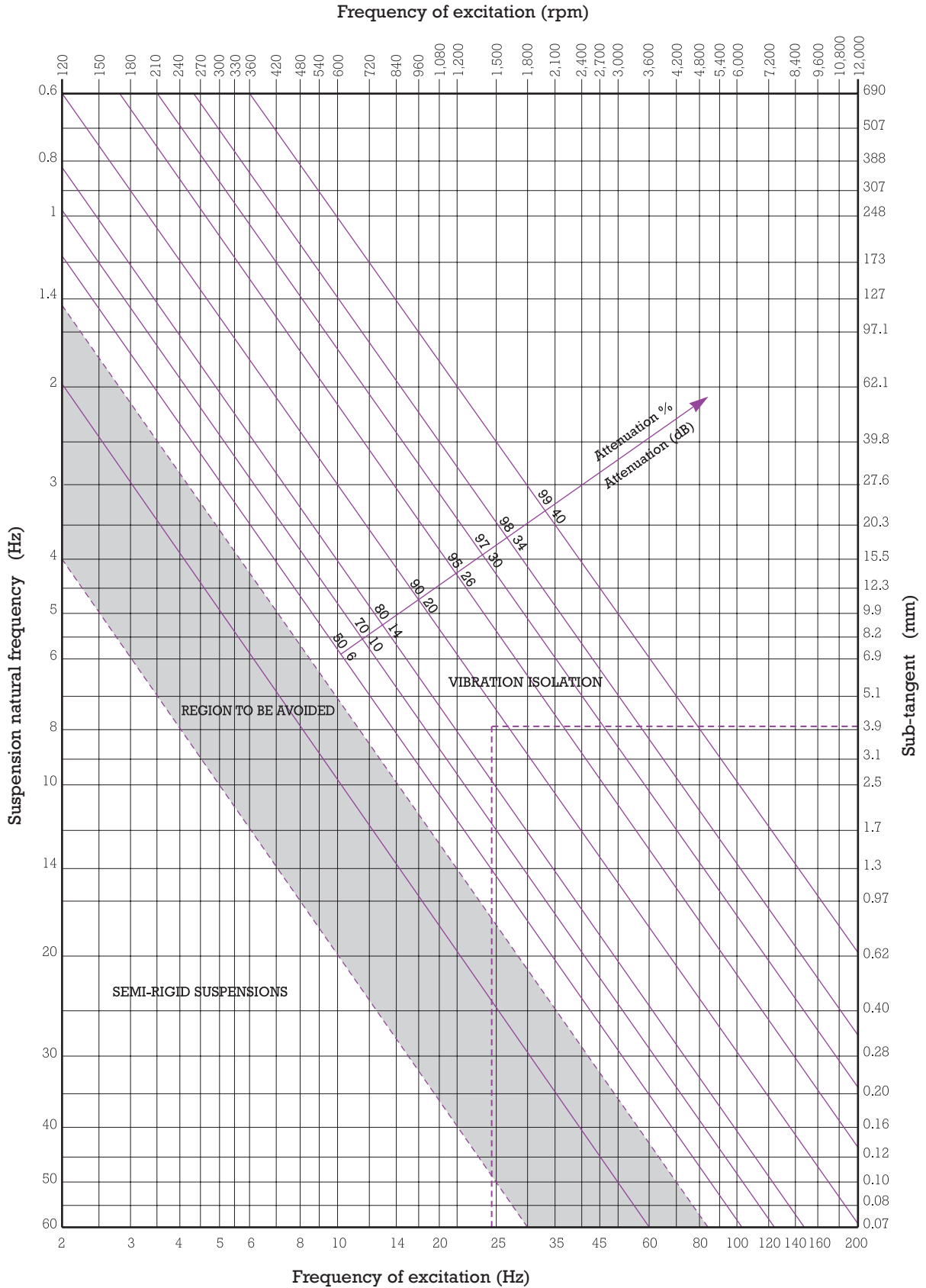

- Select the running speed (rpm) or frequency of excitation (Hz) of the equipment to be mounted, on the horizontal axis.
- Project a vertical line to intersect with a horizontal line which passes through the natural frequency of the mounting system selected.
- Where the two lines intersect, follow a diagonal line to find the level of isolation for the mounting system chosen.

Shocks

For impact machines like presses, forging hammers, etc, excitation is generated in the form of individual very short-time based shocks. In the same way as for vibration, where the importance of the relationship of f_e to f_n is paramount in determining the attenuation provided, here it is the f_n/f_s relationship (f_n : natural frequency of the mounting - f_s : shock frequency) which as to be considered.

We can deduce from these curves that:

- to obtain attenuation of a $\frac{1}{2}$ sine shock ($T < 1$) the f_n/f_s ratio must be approximately less than 0.30. Beyond this limit the excitation force is amplified. Thus for a shock lasting 0.02 second, the resonant frequency of the isolators chosen must be as low as possible and in any case must be lower than 7.5 Hz;
- the presence of damping between 0 and 0.5 of critical contributes to the attenuation of a shock, but this improvement is slight for $f_n/f_s < 0.3$.

The influence of the damping effect will be all the greater in the case of multi-frequency excitation where it is not always possible to select a natural frequency well away from the excitation frequencies. This is also true when searching for a compromise between shock attenuation (force transmission) and the limitation of displacement.

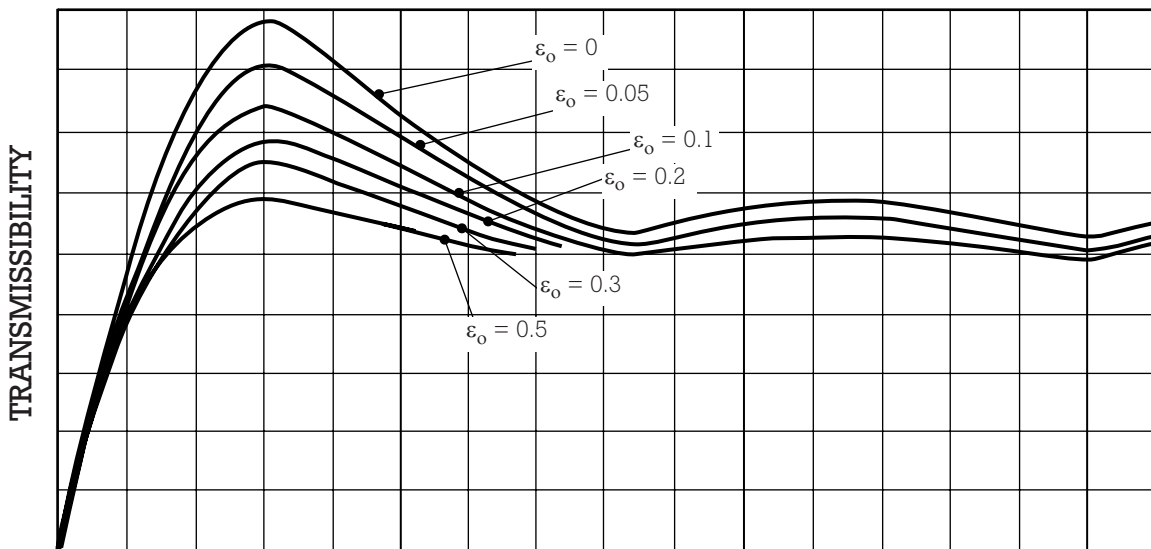

NATURAL FREQUENCY, $f_n \times$ DURATION OF SHOCK, T (secs) - FOR $\frac{1}{2}$ SINE SHOCK

III - VIBRACHOC RANGE

APPLICATION SECTORS

INDUSTRY:

- Vibration isolation of rotating machinery.
- Vibration isolation of machine tools.
- Seismic protection for civil engineering constructions.

MILITARY:

- Protection of on board electronics (tanks, shelters, vehicles, ships, submarines, etc.).
- Protection of inertial and other guidance systems.
- Protection of missiles and equipment on missiles.

MARINE AND NAVY:

- Suspension of engines and gun turrets.
- Protection of electronic racks.
- Noise reduction.

AERONAUTICS:

- Protection of electronic equipment.
- Frequency adapters for helicopters, etc.
- On board avionics mountings.

IV - INDUSTRIAL APPLICATIONS OF THE VIBRACHOC RANGE

IV.1 MACHINE TOOLS AND IMPACT MACHINERY

- Lathes, horizontal and vertical mills, tapping machines, drills, etc.
- Hydraulic and mechanical presses, shears, etc.
- High speed presses, power hammers, etc.
- Printing machinery, textile machinery, etc.

Suspension of machine tools

For example, lathes, drills, mills, planes, mortise cutters, saws, grinders, nibblers, gear cutter, borers, tapping machines, etc. The machinery is isolated actively (attenuation of the vibration generated by the machine) and passively (the machine is protected from floor vibrations).

- Vertical natural frequency between 20 and 25 Hz, provides excellent attenuation of the vibration spectrum, very effective for this type of machinery;
- Various assembly possibilities: integral levelling, non-slip base, fitting under machinery that does not have any mounting holes, etc.

Suspension of machinery for forming materials

For example: shears, folding machines, presses for punching, stamping, pressing and embossing, machinery for making nuts, hydraulic and mechanical presses, etc.

This type of machinery operates mainly by delivering blows and the shocks generated, which are sometimes significant, have to be absorbed by dampers with both a considerable capacity and high mechanical strength. The noise propagated to the structure is also noticeably reduced.

Suspension of high speed presses

The suspension has to avoid transmitting shock to the floor while maintaining the stability of the machine, particularly for automatic feed.

The dampers must be selected to avoid resonance with the machine speed:

- the machine speed may vary from 0 to 600 cycles/min;
- if the speed is greater than 250 cycles/min, highly efficient isolation is obtained by using very low frequency mountings. An integrated damping system is usually necessary (metal pad, fluid dampers, etc.).

IV.2 ROTATING AND VIBRATING MACHINERY

- Engines, generator sets, compressors, fans, crushers, centrifuges, dryers, pumps, etc.
- Sieves, riddles, engine test benches, pipework, etc.

Suspension of well balanced rotating machines

This category includes most rotating machines, which develop free forces during operation which are quite low in comparison with their mass, such as: generator sets, air conditioning plants, most engines, fans (in clean air), compressors, pumps, etc.

The choice of mounting depends mainly on the speed of rotation of the machine and the degree of attenuation required. The natural frequency of the mounting must be low for slow rotational speed and high attenuation.

The antivibration mounting protect the machine without using an inertia mass. However, the engine should be mounted on the same chassis as the driven equipment if they are not already mounted in this way, to avoid excessive stress on the couplings.

Suspension of rotating machines with high dynamic forces

Grinders, centrifuges, dryers, certain types of reciprocating compressors, pumps, engines (with 2 or 3 cylinders), etc. may generate very high forces (such as eccentric loads, unbalanced forces or torque, start-up and short-circuit torque, etc.) during operation which may affect their stability and the various connectors and hoses. It is essential to limit the displacement of the suspended equipment by ensuring that the anti-vibration system is properly designed:

- the mountings should include dampers such as metal pads, damping fluids, etc.;
- an inertial mass may be incorporated, but only if the damping obtained is insufficient to stabilise the equipment.

The design of the mounting system must cover all aspects and be carried out from the start of the equipment installation design to define the supporting structures accurately at a sufficiently early stage.

Consult us for particular solutions.

Passive suspension of rotating machines

Certain types of compressors are perfectly balanced and do not generate any significant vibration. However, their operation and setting are so sensitive to vibration or shock (nearby workshops, handling, etc.) that they need passive protection.

The machine should be mounted on an inertial mass suspended on mountings with springs and metal pads.

Suspension of on-board rotating machines

On board lorries, trailers, trains, road and rail vehicles, boats, etc.

In addition to active protection, the machine needs to be protected against shocks and vibrations generated by the vehicle.

“Captive” mountings are usually used. They have travel limiting stops in all directions to ensure absolute safety while the vehicle is moving.

Suspension of vibrating machinery

Suspending sieves, vibrating riddles, etc... is more complex because these machines already have elastic couplings (e.g. springs) which assist operation.

If the machine is suspended on vibration mountings, it becomes a two-stage vibration system. When designing these systems the natural frequency of the elastic couplings within the machines as well as any flexibility in the chassis have to be taken into account.

Suspending engine test benches

This type of equipment poses a special vibration problem:

- the forces generated may be very high and sudden.
- the equipment must be able to be used with engines that vary considerable in size, weight and power.

An effective solution is to use an inertia mass suspended on very low frequency mountings with adequate integral damping.

IV.3 VEHICLES

- **Civil engineering plants**
- **Handling equipment**
- **Lorries**
- **Trailers**
- **Road vehicles**
- **Railway engines**

Particular attention must be paid to elastic mountings for equipment on Civil Engineering plant and vehicles in general. **The relative elasticity of the structures must often be taken into account as they can generate low or very low frequency vibration as a result of shocks arising from the work or movement.**

To be effective - the elastic mounting - must, therefore, be carefully designed.

The following examples, in particular for cabs, seats and equipment, are given for illustration only. The right solution may vary considerably from one machine to another.

Suspension of propulsion systems

The problem here is to minimise the vibration and noise generated by the engine through the structure of the vehicle (structure borne).

The disturbing frequencies vary from 10 to 100 Hz (and harmonics) for engines and 120 to 400 Hz for gear boxes.

The damping system should usually have:

- a low (isometric) resonant frequency (if possible 6-8 Hz);
- a limited displacement under extreme forces (system with very progressive stiffness);
- considerable low frequency damping and as low as possible above 100 Hz.

IV.4 MARINE-OFFSHORE

The vibration and noise on board ships is generated by:

- the system of propulsion: the alternating hydro-dynamic forces generated by the propellers pass through the hull, usually creating low frequency vibration;
- the main engines and auxiliary engines which transmit vibrations to the hull via the structure: the spectrum is usually in the 15-50 Hz region;
- the exhausts: spectrum 16-8000 Hz;
- the effects of the sea: swell, heavy seas, wind;
- accidental shocks against the quays.

Regulations have been drawn up to protect the crews, passengers and equipment from discomfort caused by shocks and noise.

The VIBRACHOC range provides a comprehensive selection of means for complying with the standards and regulations for vibration and noise on ships (ask us for details).

Suspension of main engines and auxiliary engines

The main engines and auxiliary engines transmit vibrations to the structure of the ship. They also emit noise:

- directly into the air;
- indirectly, as the structures linked rigidly to the engine themselves become sources of transmitted noise.

Mountings (dampers) at strategic places between the engine and the structure **significantly reduce the structure borne vibration and noise**.

Many parameters are required for calculating the suspension required for marine engines: the rotation speed of the engine, the number of cylinders, the number of blades on the propeller, the natural frequency of the hull, the elastic coupling characteristics, the roll, the pitch and the maximum permitted forces. The technical service of Paulstra, Vibrachoc and Stop-Choc has several computer calculation programmes to define the most suitable suspension.

An extensive range of all metal or elastomer based dampers is available for mounting all kinds of engines:

- **diesel engines** of all sizes for merchant ships, war ships or pleasure boats;
- **auxiliary engines**, generators, pumps, compressors, windlasses, etc.

Suspending exhaust pipes

The turbulent gases circulating in exhaust pipes are a source of vibration and noise. Using elastic mountings to anchor exhaust pipes from diesel engines has the advantages of:

- reducing the vibrations transmitted to the structure of the ship;
- attenuating the global noise in areas near the funnels, by between 5 and 20 dB (A);
- eliminating expansion compensators, as the mounting allows free expansion of the ducts;
- eliminating the deformation of the pipes caused by rigid mountings. The suspension of an exhaust pipe usually requires supports and stabilisers.

Suspension of on board equipment

Elastic suspension of sensitive on-board equipment (radio, navigation, electric or electronic enclosures, control panels, etc) provides protection against vibration coming from the structure. On board warships, high deflection mountings also provide protection against shocks from mines, etc. Stabilisers have to be added to supporting dampers for tall enclosures or racks.

IV.5 BUILDINGS

The problem of preventing vibration caused by air conditioning, ventilation, compressor or pumping systems, etc, in housing (flats, hotels, etc) offices or factories is now becoming more common for two reasons:

- 1) There is a general tendency to reduce the vibration and noise levels to comply with new noise regulations.
- 2) There is also a general tendency to build lighter constructions with greater spans, implying greater floor flexibility.

Active damping of machinery by preventing vibration being transmitted through the structure of buildings is often a way of complying with these regulations. The mechanical vibration filtered by VIBRACHOC mountings is transmitted at a level that is too low to excite structures that could create noise.

Suspension of foundations of lifts, hoists, etc

The vibration generated by the winch while operating a lift has to be damped but it is especially important to absorb the shock generated when the machine starts or brakes. This often requires the use of elastic systems with good damping.

Suspension of fans, air conditioning, compressors, pumps, etc

An elastic suspension provides good protection against vibration, **while, in most cases, avoiding the need for concrete masses, a costly solution** which prevents the equipment being moved easily.

The vibration and noise generated by a machine are more of a nuisance to the environment if they are positioned at a structurally weak point (roofs, terraces, floors, etc) and near offices or flats.

The rigidity of the floor is a factor that has to be taken into consideration when deciding which type of suspension to use.

Suspension of floating slabs

An economical solution is not to mount each machine separately but to group all the equipment likely to cause vibration on one slab, said to be floating because it is linked to the structure of the building by very low frequency mountings.

This system considerably increases the inertia of the suspended part and thus significantly reduces the displacement of the slab.







Suspension of pipework and conduits

Pipes and conduits generate two types of vibration:

- low frequency vibration due to turbulent flow (8-15 Hz),
- high frequency vibration due to the vibration of the pipes themselves (above 25 Hz).

The suspension usually also has to withstand quite high temperatures and allow the pipes to expand freely, which means that elastic all metal and/or telescopic systems have to be used.

SELECTION GUIDE OF MOUNTINGS





	AXIAL FLEXIBILITY	AXIAL AND RADIAL FLEXIBILITY + ANTI-REBOUND				AXIAL FLEXIBILITY	
Product range →	V4* VIBSOL PDM-1000 PDM-2000 SP55*W SP56*W V120 & V125	V118-DG V118-MG V318 V318-D V1H5023 V1H5025	V164 V168	V402-MG	V1H751 V1H752	SP539-***	
Nominal static load in daN							
5	Natural frequency = 10 to 25 Hz		Natural frequency = 8 to 22 Hz				
10							
20							
30							
50			Natural frequency = 11 to 25 Hz		Natural frequency = 15 to 22 Hz		
70							
100							
200							
300							
400							
500							
600							
700							
800							
900							
1 000							
2 000							
3 000							
4 000							
5 000							
6 000						Natural frequency = 10 to 16 Hz	
7 000							
8 000							
15 000							
140 000							
280 000							

Warning:

At least two parameters are necessary to select a mounting system: the load to be supported and the excitation frequency or running speed of the equipment to be isolated. This frequency or speed needs to have the correct relationship with the natural frequency of the mounting system (see graph on page 7). If this relationship is ignored there is a risk that the vibration will be amplified.







* = indicates the stiffness of the mount.

SELECTION GUIDE OF MOUNTINGS

AXIAL AND RADIAL FLEXIBILITY + ANTI-REBOUND	AXIAL AND RADIAL FLEXIBILITY	AXIAL AND RADIAL FLEXIBILITY + ANTI-REBOUND	AXIAL FLEXIBILITY	MULTIAXIAL FLEXIBILITY	
V1H-6000 V1H-6100	V1B1114 V1B1115 V1B1116 V1B1134 V1B1135 V1B1136 V1209-V1210	7002 MV801 MV803	VE101 VE111 VE112 VE113 VIN30*	VIBCABLE	Product range ←
					Nominal static load in daN
					5
					10
Natural frequency = 12 to 18 Hz		Natural frequency = 5 to 10 Hz			20
					30
					50
					70
					100
					200
					300
					400
					500
					600
					700
					800
					900
					1 000
					2 000
					3 000
					4 000
					5 000
					6 000
					7 000
					8 000
					15 000
					140 000
					280 000



Note: Natural frequencies are given in axial.

APPLICATIONS GUIDE TO VIBRACHOC METAL RANGE

	AXIAL FLEXIBILITY		AXIAL & RADIAL FLEXIBILITY + ANTI-REBOUND			
Product range →	Metal cushions & V1B5984	V4* VIBSOL PDM-1000 PDM-2000 SP55*W SP56*W V120 & V125	V118-DG V118-MG V318 V318-D	V164 V168	V402MG	V1H751 V1H752
APPLICATIONS						
ELECTRICAL ENCLOSURE						
LIFT						
CRUSHER						
VEHICLE CAB						
AIR CONDITIONING						
SIEVE						
GENERATOR SET						
MACHINE TOOLS						
SHIPBOURNE EQUIPMENT						
LABORATORY EQUIPMENT						
IC ENGINES						
COMPRESSORS						
PUMPS						
GEARBOXES						
FANS						
CIVIL ENGINEERING						
CEILINGS, PIPEWORK						
GANTRIES						
GUILLOTINES						
SCREEN						
TRANSFORMER						
HOPPER						
PIPEWORK						

For mobile installation: V118, V318, V402, V1H751 or 752, V1H-6000 or 6100, 7002, VIBCABLE.

APPLICATIONS GUIDE TO VIBRACHOC METAL RANGE

AXIAL FLEXIBILITY	AXIAL & RADIAL FLEXIBILITY + ANTI-REBOUND	AXIAL & RADIAL FLEXIBILITY	AXIAL & RADIAL FLEXIBILITY + ANTI-REBOUND	AXIAL FLEXIBILITY	MULTIAXIAL FLEXIBILITY	
SP539-***	V1H-6000 V1H-6100	V1B1114 V1B1115 V1B1116 V1B1134 V1B1135 V1B1136 V1209 - V1210	7002 MV801 MV803	VE101 VE111 VE112 VE113 VIN30*	VIBCABLE	Product range ←
			 			APPLICATIONS
		Fix				ELECTRICAL ENCLOSURE
						LIFT
						CRUSHER
						VEHICLE CAB
						AIR CONDITIONING
						SIEVE
						GENERATOR SET
						MACHINE TOOLS
			7002			SHIPBOURNE EQUIPMENT
						LABORATORY EQUIPMENT
						IC ENGINES
						COMPRESSORS
						PUMPS
						GEARBOXES
						FANS
						CIVIL ENGINEERING
						CEILINGS, PIPEWORK
						GANTRIES
						GUILLOTINES
						SCREEN
						TRANSFORMER
						HOPPER
						PIPEWORK

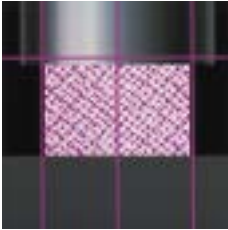

METALLIC CUSHIONS



(1) Natural frequency:
10 to 25 Hz

DESCRIPTION

Metallic cushions are made from drawn, woven stainless steel wire that is compressed into a geometric shape.

The Vibrachoc range has more than 1000 standard metallic cushions of various sizes and characteristics.

As metallic cushions are easy to create, custom shapes and characteristics can be developed and produced on request.

APPLICATIONS

Standard or custom metallic cushions can be used for many industrial applications because they are naturally resistant to grease, oil, water, etc and withstand temperatures from - 70°C to + 300°C.

The static stiffness of the metallic cushion ensures progressive stiffening and maintains a constant natural frequency for a very wide range of loads within a small space.

Their natural frequency of between 12 and 25 Hz and damping of 15 to 20% make them suitable for mounting rotating machines with a rotation speed over 2000 rpm.

(1) Natural frequencies with max/min loads, see: OPERATINGS.

DIMENSIONS

• SIMPLE CYLINDRICAL SHAPE

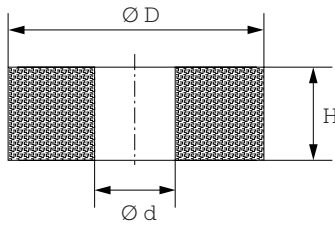

Reference	Ø Ext. D mm	Ø Int. d mm	Height H mm	Load range daN	Dynam. force daN	Natural frequency Hz
VI168-B	53	16.5	14	20 to 250	1250	15 to 22
V3CNVI653-A02	33	14	19	75 to 300	900	15 to 22
CH440-A02	72	50	21	50 to 350	1000	15 to 20
VI771-A02	40	15	20	150 to 550	1700	15 to 20
MC345-A02	72	34	21	300 to 1300	5000	15 to 20
CH281-A02	119	34	21.5	700 to 2700	12500	15 to 20
CH283-A02	159	70	21.5	250 to 7000	22500	15 to 20
VI996-A02	203	121	21	250 to 7000	22500	15 to 20
CH438-A02	72	51	10	50 to 350	1000	20 to 25
CH265-A02	70	34	10.5	300 to 1300	5000	20 to 25
CH264-A02	116	36	11	700 to 2700	8000	20 to 25
VI771-B02	40	15	11.5	750 to 3000	9000	20 to 25
CH472-A02	156	72	10.5	2000 to 7000	21000	20 to 25

For cushions with alternative dimensions and load ranges, please consult us.

1 kg ≈ 1 daN

• CYLINDRICAL SHOULDERED SHAPE

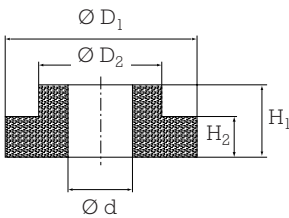

Reference	Ø D ₁ mm	Ø D ₂ mm	Ø int. d mm	H ₁ mm	H ₂ mm	Static load daN	Dynam. force daN	Natural frequency Hz
VJ148-A05	72	48	33	25	21	50 to 350	1050	15 to 20
V3CNCH682-A05	69.5	52	34	30	23.5	50 to 300	900	15 to 20
V3CNVJ044-A05	52.6	26.5	16	21.5	14	25 to 200	600	15 to 22
V3CNVJ102-A05	49	27.5	18	30	24.5	20 to 100	300	15 to 20
VJ164-A05	34.5	20	12.5	14	10	15 to 100	300	20 to 25

1 kg ≈ 1 daN

• RECTANGULAR SHAPE

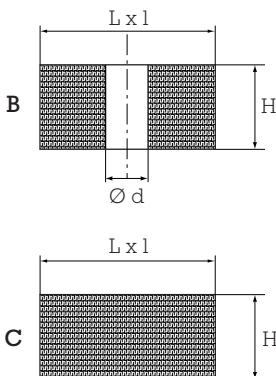

Reference	Shape	Dim. L x l mm	Ø int. d mm	H mm	Static load daN	Dynam. force daN	Natural frequency Hz
VI786-A06 *	B	53 x 49	8	25	30 to 200	800	12 to 18
VI830-B06	C	28 x 28	-	15	50 to 300	1000	17 to 22
VI700-A06 *	C	50 x 47	-	25	75 to 400	1200	12 to 18
VI700-B06 *	C	50 x 47	-	16	75 to 400	1600	17 to 22
CH422-A06	C	45 x 36	-	16	400 to 1500	5000	20 to 25
V3CNVI 034-A06	B	100 x 100	-	34	2000 to 7000	20000	12 to 18
VJ149-A06	B	28 x 28	10.5	10	25 to 150	450	20 to 25
V3CNVJ006-A06	B	157 x 157	30	25	500 to 5000	15000	13 to 18

*: References detailed on following pages.

1 kg ≈ 1 daN



ASSEMBLY EXAMPLES

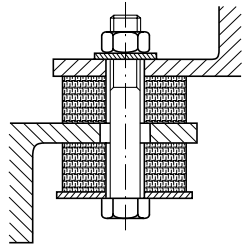

Suspension of gearboxes, motors, fans, pumps, axial load only.
A gap is necessary around the fixing screw.

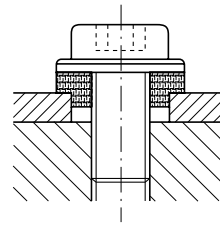

Absorbs expansion and isolates screws under dynamic load.

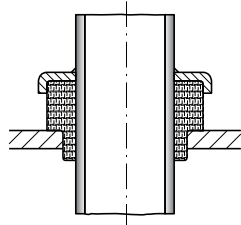

Pipe isolation.

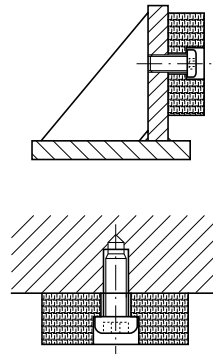

Suspension of motors, fans, etc.

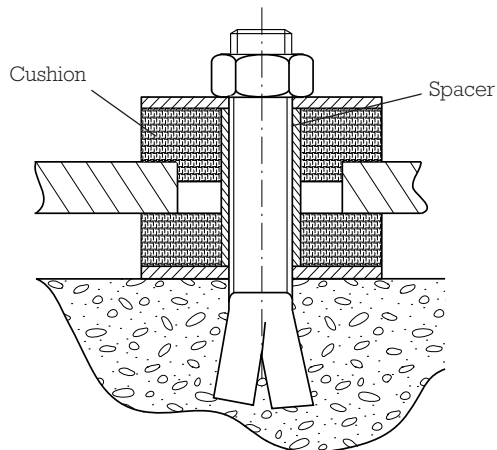

Scheme showing a cushion mounting with uplift snubber.

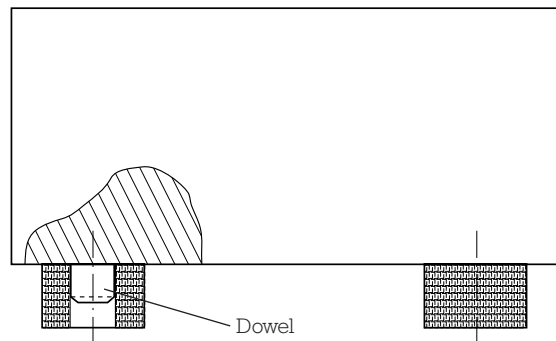

Machine mounted on cushions located on dowels.

OPERATING CHARACTERISTICS

TYPICAL STIFFNESS CURVE FOR A METALLIC CUSHION

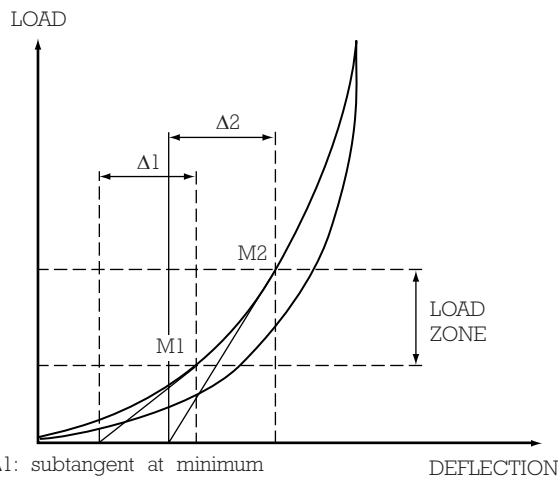

$\Delta 1$: subtangent at minimum load M1.
 $\Delta 2$: subtangent at maximum load M2.
 $\Delta 1 = \Delta 2$

Natural frequency of the mounting remains constant in the load zone.

The elastic limit of the metallic cushion under compression is 3 to 5 times greater than the maximum static load shown in the data sheets.

- 1 - Excellent resistance to oil, grease, solvents, water, dust, chemical agents.
- 2 - Withstands temperatures from -70°C to $+300^{\circ}\text{C}$ and in certain applications -150°C to $+400^{\circ}\text{C}$.
- 3 - Highly resistant to ageing: characteristics are stable.
- 4 - High damping from 15 to 20%, i.e. $\tan \delta$ from 0.3 to 0.4 corresponding to an amplification factor at resonance < 4 .
- 5 - Loading up to 150 kg/cm^2 under compression and 500 kg/cm^2 for isolating shocks.
- 6 - Natural frequency between 15 and 25 Hz.

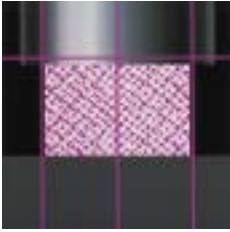

VIBSOL®

New !

(1) Natural frequency:
15 to 30 Hz



DESCRIPTION

- The VIBSOL mount is made of a round metal cushion covered with an anti-slip elastomer pad on both side.
- It is available in two versions:
 - a standard version with a natural frequency of 22 to 30 Hz (machine tools).
 - a thick version (W) with lower stiffness and a natural frequency of 15 to 22 Hz (metal forming machines).

APPLICATIONS

- The VIBSOL mount is a simple and quick solution for machine tools offering a good shock absorption, and easy to install by sliding it under the base of the machine.
- Unaffected by oils, cutting fluids, detergents, high and low temperatures with good resistance to fatigue.
- It offers good stability for the suspended machine.
- A constant natural frequency over a wide load range makes mount selection easy.

(1) Natural frequencies with max/min loads, see: OPERATING CHARACTERISTICS.

DIMENSIONS

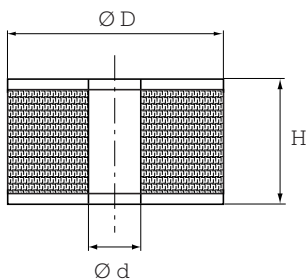

Type	Part number	Ø D mm	Ø d mm	Height H mm	Load range daN	Natural frequency Hz
VIBSOL 43	V6080 F43	72	51	12	50 - 350	22 - 30
VIBSOL 43W	V6080 F43W	72	50	23	50 - 350	15 - 22
VIBSOL 44	V6080 F44	70	34	13	300 - 1300	22 - 30
VIBSOL 44W	V6080 F44W	70	34	23	300 - 1300	15 - 22
VIBSOL 45	V6080 F45	116	36	13	700 - 2700	22 - 30
VIBSOL 45W	V6080 F45W	116	34	24	700 - 2700	15 - 22
VIBSOL 46	V6080 F46	156	72	14	2000 - 5000	22 - 30
VIBSOL 46W	V6080 F46W	156	70	24	2000 - 5000	15 - 22

1 kg ≈ 1 daN

These referencies are kept in stock, see current price list for availability of items.

OPERATING CHARACTERISTICS

Vibration attenuation

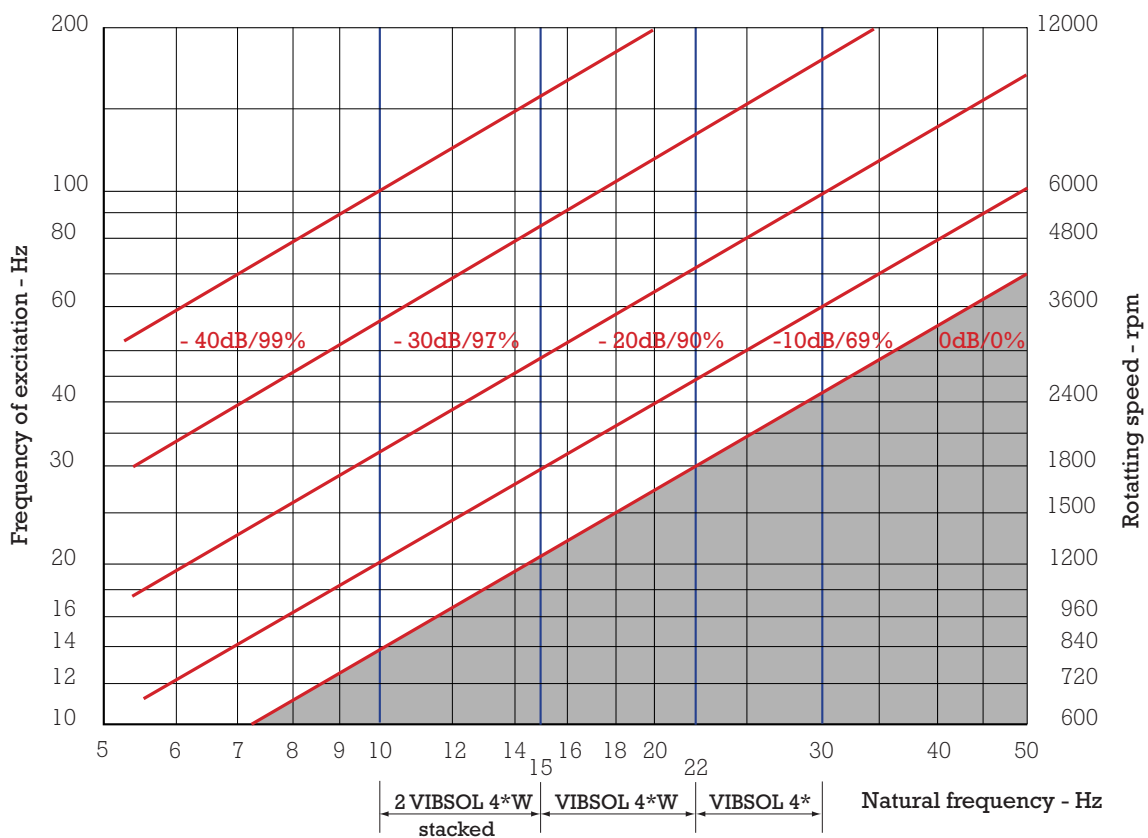

VIBSOL mountings

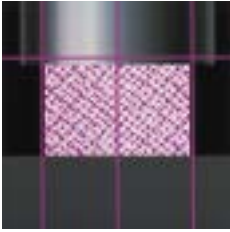

VI786-A06

VI700-A06

VI700-B06



(1) Natural frequency:
15 to 20 Hz

DESCRIPTION

This suspension system consists of rectangular cushions made of woven compressed stainless steel wire. The VI786 have a $\text{Ø } 9$ bored screw hole, so that they can be mounted in collars with the diameters required by the user.

APPLICATIONS

This suspension system is particularly suitable for mounting exhaust pipes from generator sets on board ship or permanently mounted in buildings. They are unaffected by aggressive chemicals, oil, grease and corrosion and withstand extreme temperatures from $- 70^{\circ}\text{C}$ to $+ 300^{\circ}\text{C}$.

The natural frequency of between 15 and 20 Hz enables the pipes to be mounted independently of the support and thus reduces noise levels and allows the pipes to expand freely.

(1) Natural frequencies with max/min loads, see: OPERATING CHARACTERISTICS.

DIMENSIONS

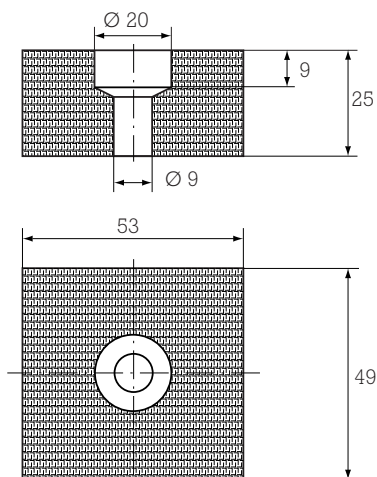

Assembly:

Countersunk screws can be used to mount the cushions inside the collar.

The number of cushions used should be a multiple of 4, depending on the diameter of the pipework: see table below.

However, for small diameter pipes, 2 collars can be used edge to edge, each having 2 pads at opposite diagonals.

OPERATING CHARACTERISTICS

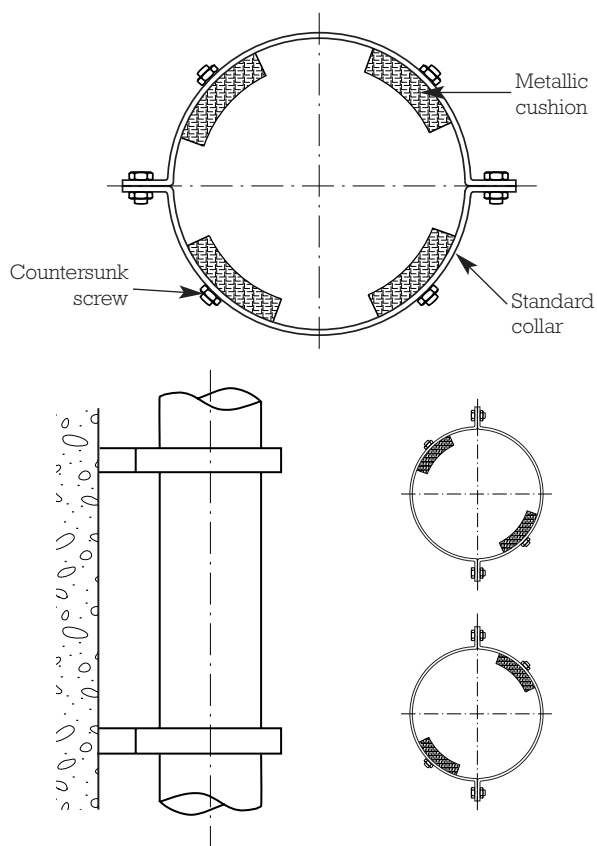

Ø of the pipe mm	Number of cushions
75 - 175	4
175 - 425	8
425 - 550	12
550 - 700	16
700 - 850	20
850 - 1000	24
1000 - 1150	32
1150 - 1300	36
1300 - 1450	40
1450 - 1600	44
1600 - 1750	48

Max. dynamic force in compression: 800 daN.
Static load range from 30 to 200 daN.

Collars and screws not supplied.

VI700-A06 - VI700-B06

DIMENSIONS

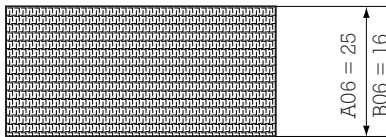
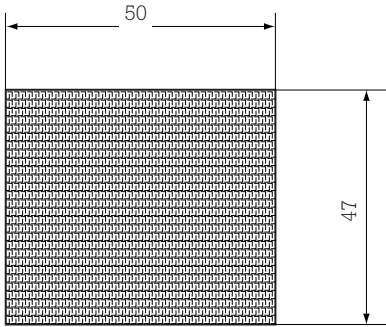

Assembly:

Our wide range of mountings can meet many requirements. These mountings should be used as shown in the following diagram (two half collars, in which the cushions are placed side by side, are connected to the structure).

Note: the cushions may be mounted in two orientations: the height H is shown on the table. Refer to the drawing to ensure that the height H is correct when mounting.

Choice:

The cushions are 16 mm or 26 mm thick. We advise using VI700-B06 pads (16 mm thick) for $\varnothing D$ pipes < 270 and VI700-A06 (25 mm thick) for $\varnothing D$ pipes > 270.

For example:

- for $\varnothing D$ ext 140 pipe: use 9 VI700-B06 cushions;
- for $\varnothing D$ ext 1000 pipe: use 61 VI700-A06 cushions.

OPERATING CHARACTERISTICS

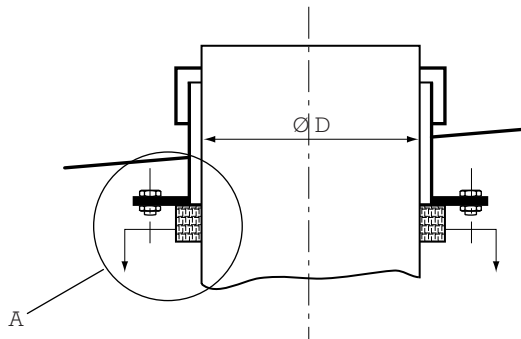

Use spacers between the half collars to allow for future tightening

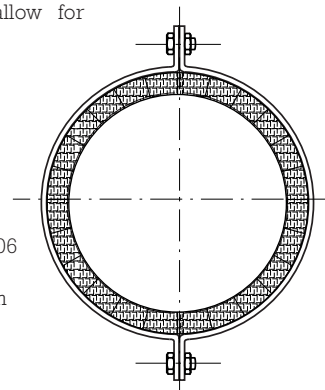

Cushions VI700-A06 (25 mm thick) or VI700-B06 (16 mm thick)

DETAIL A

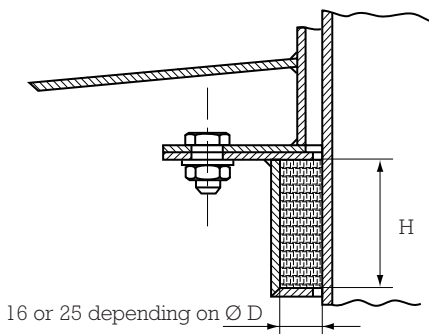

Pipe $\varnothing D$ mm	H mm	Numb. of cushions
75 to 85	50	5
80 to 90	47	5
90 to 100	50	6
95 to 105	47	6
105 to 120	50	7
120 to 135	50	8
135 to 150	50	9
150 to 170	50	10
165 to 185	50	11
180 to 200	50	12
195 to 220	50	13
210 to 240	50	14
240 to 270	47	15
270 to 305	47	17
300 to 340	50	20

Pipe $\varnothing D$ mm	H mm	Numb. of cushions
335 to 380	47	21
360 to 410	50	24
400 to 450	50	27
445 to 500	47	28
500 to 560	47	31
560 to 630	47	35
620 to 700	47	39
700 to 790	47	44
780 to 880	47	49
875 to 985	47	55
975 to 1100	47	61
1100 to 1240	47	69
1230 to 1385	47	77
1370 to 1550	47	86
1530 to 1725	47	96

Maximum dynamic force in compression: VI700-A06 = 1200 daN
VI700-B06 = 1600 daN

Static load range from 75 to 400 daN



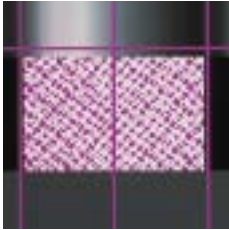

METALLIC CUSHIONS FOR PIPEWORKS



(1) Natural frequency:
depending on load

DESCRIPTION

The metal cushions for pipework are made from stainless steel wire that is work hardened, knitted, crimped and compressed to a given shape in a press.

The cushion can be supplied on its own or in a mounting kit which comprises two cushions, two spacers, a retaining zinc plated steel clamp.

APPLICATIONS

The cushions are resistant to temperatures from - 70°C to + 300°C and are used to clamp and isolate pipes against vibration.

(1) Natural frequencies with max/min loads, see: OPERATING CHARACTERISTICS.



DIMENSIONS

- CUSHION ONLY

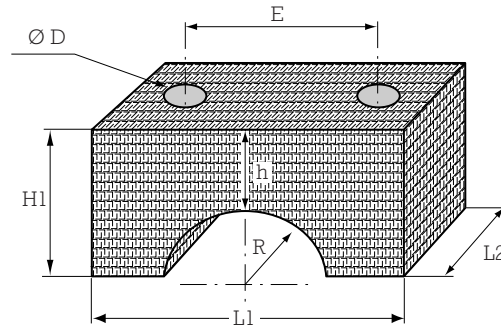

Reference for cushion only	R mm	L1 mm	L2 mm	H1 mm	h mm	Ø D mm	E mm
000 51 430	5.10	60	30	15	12	7	40
000 51 431	6.75	60	30	15	12	7	40
000 51 432	8.60	70	30	20	16	7	50
000 51 433	10.65	70	30	20	14	7	50
000 51 423	16.50	87	31	30	20	9	65
000 51 422	24.00	88	32	30	15	9	65
V3CNVJ123-A06	20.00	115	35	35	15	13.5	85
V3CNVJ122-A06	25.00	115	35	35	15	13.5	85
V3CNVJ121-A06	30.00	115	35	35	15	13.5	85

Dimensions are for unloaded cushions.

- CUSHION KIT (Screws not supplied)

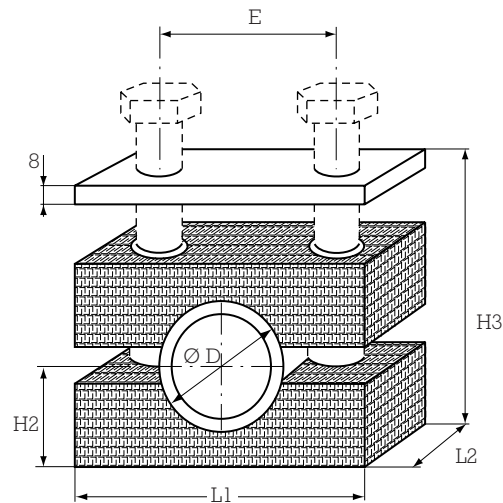

Kit reference	Ø D mm	L1 mm	L2 mm	H2 mm	H3 mm	E mm
V6056K01	40	115	35	32,5	73	85
V6057K01	50	115	35	37,5	83	85
V6058K01	60	115	35	42,5	93	85

Dimensions are for loaded cushions.



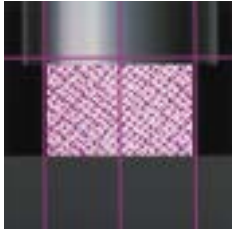

V43 V44
V45 V46

- (1) Natural frequencies:
V4* = 22 to 30 Hz
V4*W = 15 to 22 Hz

See also PAULSTRA
elastomer range:
Nivofix - Minifix

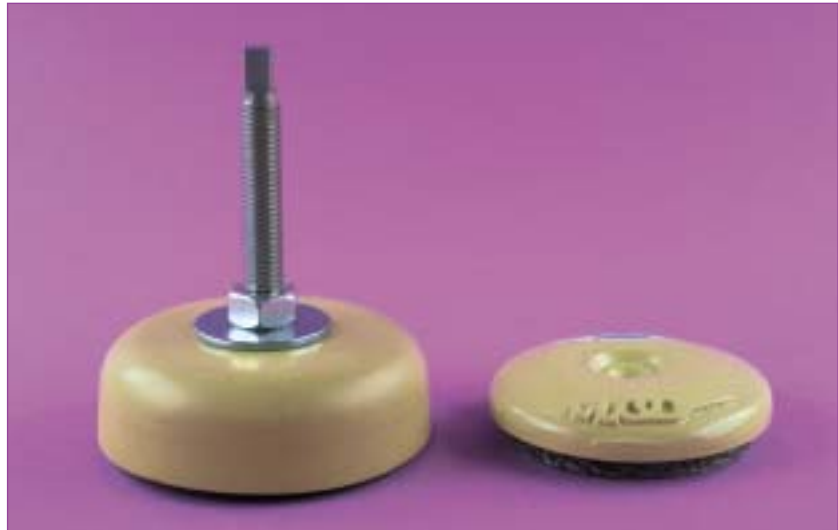

DESCRIPTION

Standard V43, V44, V45 and V46 mountings have a cast steel base and a resilient element made from a stainless steel wire cushion.

The version H includes a cup and a levelling stud. It can also be equipped with grip pads.

Version W differs from the standard version as it has a thicker cushion for greater flexibility.

APPLICATIONS

This range with a natural frequency of 15 to 30 Hz can be used for mounting machine tools in harsh industrial environments.

They are unaffected by oil, temperature and fatigue and their life time is often the same as that of the machine.

The thicker metallic cushion of the version W, can be used for mounting forming tools (presses, shears, folding machines) and improves the vibration isolation level.

(1) Natural frequencies with max/min loads, see: OPERATING CHARACTERISTICS.

MOUNTING AND ACCESSORIES

This range of mountings is available complete or the parts can be obtained separately:

OPTION
Levelling kit



Part number

- KT43H
- KT44H
- KT45H
- KT46H

Complete mounting with levelling device

(includes a stainless steel cushion glued under a cast iron cup + a levelling kit)

Standard cushion	Thick cushion
V43-H	V43-WH
V44-H	V44-WH
V45-H	V45-WH
V46-H	V46-WH

MOUNTING
All metal cushion mount with cast iron housing



Part number for basic version

Standard cushion	Thick cushion
V43	V43-W
V44	V44-W
V45	V45-W
V46	V46-W

OR

OPTION
Antislip pad



Accessory part number

- KT43G
- KT44G
- KT45G
- KT46G

OPTION
Base fixing



Part number

- KT43F
- KT44F
- KT45F

DIMENSIONS

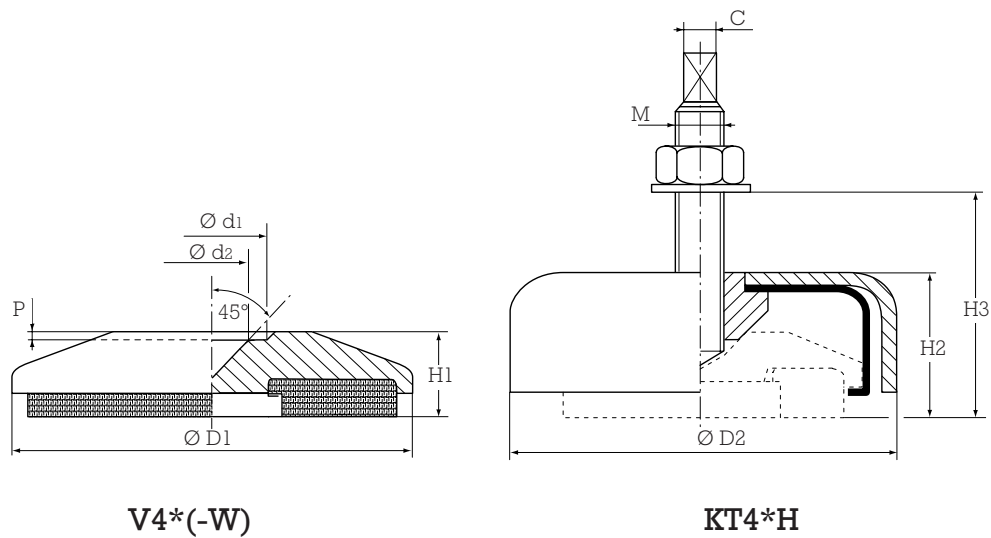

V4*(-W)

KT4*H

* Complete part number; see table below.
W = Low frequency cushion.

OPERATING CHARACTERISTICS

Reference	Static load daN	Max. dynamic force in compression daN	Natural frequency Hz	Ø D1 mm	H1 mm	Ø D2 mm	H2 mm	M	C mm	H3 maxi mm	Ø d1 mm	Ø d2 mm	P mm	
V43	50 to 350	750	22 to 30	81	20	-	-	-	-	-	17	12	3	
V43-H				-	-	96	35	M12	8	115	-	-	-	
V43-W			15 to 22	81	31	-	-	-	-	-	-	17	12	3
V43-WH				-	-	96	46	M12	8	125	-	-	-	
V44	200 to 1300	4000	22 to 30	81	20	-	-	-	-	-	17	12	3	
V44-H				-	-	96	35	M16	10	135	-	-	-	
V44-W			15 to 22	81	31	-	-	-	-	-	-	17	12	3
V44-WH				-	-	96	46	M16	10	147	-	-	-	
V45	700 to 2700	8000	22 to 30	128	26	-	-	-	-	-	33	18	3	
V45-H				-	-	152	45	M20	13	155	-	-	-	
V45-W			15 to 22	128	36.5	-	-	-	-	-	-	33	18	3
V45-WH				-	-	152	56	M20	13	163	-	-	-	
V46	2000 to 5000	15000	22 to 30	170	34.5	-	-	-	-	-	44	28	4	
V46-H				-	-	190	60	M24	16	160	-	-	-	
V46-W			15 to 22	170	43.5	-	-	-	-	-	-	44	28	4
V46-WH				-	-	190	71	M24	16	170	-	-	-	

1 kg ≈ 1 daN

Maximum excitation at resonant frequency: ± 0.2 mm (± 0.4 mm with low frequency cushion, suffix W).

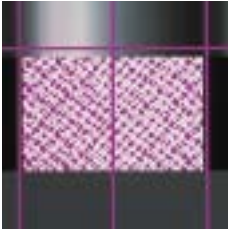

V47 V47D
V47T V47Q



(1) Natural frequency:
8 to 20 Hz

DESCRIPTION

- Anti-vibration mounting available with a constant natural frequency over a wide load range.
- Cast iron base and levelling device.
- Conical wire mesh cushion, capable of narrying lateral loads.
- V47D version has a stack of two cushions with a cast iron separating cup.
- V47T and V47Q have three and four metal cushions respectively.

APPLICATIONS

This machinery mount, with adjustable height, is used for machine tools and other rotating machine.

The V47 and V47D are designed for presses and printing machines.

(1) Natural frequencies with max/min loads, see: OPERATING CHARACTERISTICS.

DIMENSIONS

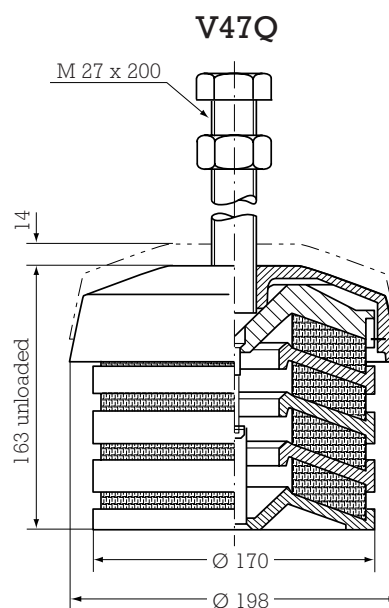
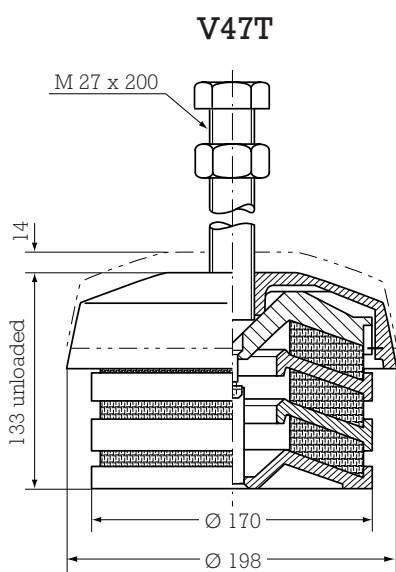
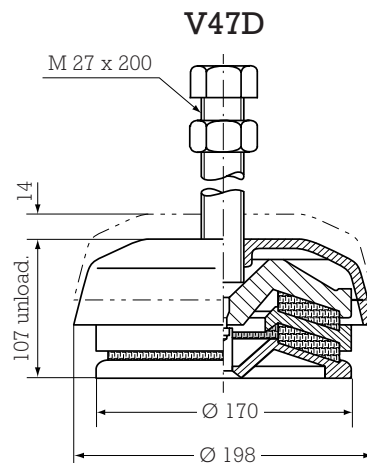
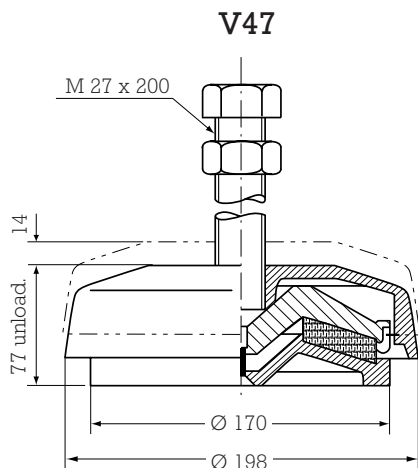

OPERATING CHARACTERISTICS

Reference	Load range daN	Max. dynamic force daN	Natural frequency Hz	Weight of mounting kg
V47	250 to 7000	21 000	15 to 20	9.1
V47D	250 to 7000	21 000	12 to 16	12.2
V47T	250 to 7000	21 000	10 to 13	13.1
V47Q	250 to 7000	21 000	8 to 11	15.1

1 kg \approx 1 daN

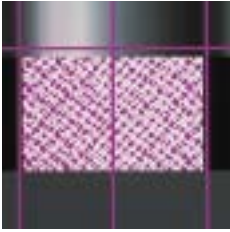

PDM-1000-01

PDM-2000-01

100%
Stainless steel

(1) Natural frequency:
15 to 18 Hz



DESCRIPTION

Low profile mountings with high static and dynamic load range.

- 100% 316 **stainless steel**.
- Natural frequency from 15 to 18 Hz.
- Dynamic load in compression: 3 g.
- Maximum sinusoidal input at resonance: ± 0.4 mm.

APPLICATIONS

- Anti-vibration mounting for presses and machine tools without the need to fix or grout in position.
- For chemical, food industry ...

OPERATING CHARACTERISTICS

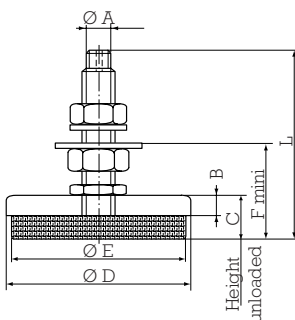

Reference	Static load daN	Ø A	B mm	C mm	Ø D mm	Ø E mm	F mm	L mm
PDM-1000-01	200 to 1000	M12 M16	18	27	80	73	52	156
PDM-2000-01	800 to 2000	M16 M20	15	30	128	120	62	197

1 kg \approx 1 daN

(1) Natural frequencies with max/min loads, see: OPERATING CHARACTERISTICS.



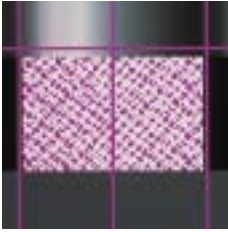

SP550W, 551W, 552W, 553W SP560W, 561W, 562W, 563W



(1) Natural frequency:
15 to 20 Hz

DESCRIPTION

Machine mount available with a stud (SP55*W) or threaded hole (SP56*W).

- Top cup and stud are mild steel zinc plated.
- Stainless steel wire mesh cushion.
- Natural frequency between 15 to 20 Hz.

SP55*W

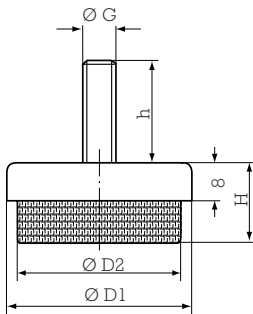

SP56*W

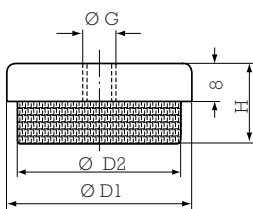

APPLICATIONS

- Mounting for low loads.
- Suitable for rotating machines (> 2500 rpm) and laboratory equipment ...

OPERATING CHARACTERISTICS

Reference with thread. stud	Reference with tapped hole	Ø D1 mm	Ø D2 mm	H mm	h * mm	Ø G	Static load daN	Deflection under load daN
SP550W	SP560W	28	23.6	17.5	20	M6	60	4.2
SP551W	SP561W	40	34.5	17	20	M6	100	4.8
SP552W	SP562W	45	40	22	25	M8	150	5.6
SP553W	SP563W	58	53.6	22	25	M8	225	6.3

* SP55*W only.

1 kg ≈ 1 daN

(1) Natural frequencies with max/min loads, see: OPERATING CHARACTERISTICS.

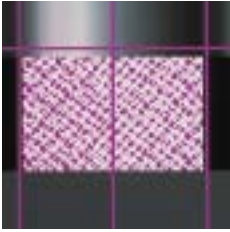

SP539-882 SP539-883
SP539-887 SP539-888



(1) Natural frequency:
8 to 16 Hz

DESCRIPTION

All metal mounting comprising a stack of between one and three woven steel cushions giving a variation in natural frequency depending upon the number of cushions. This make higher levels of isolation possible.

The stainless steel cushions in conical shape are capable of carrying radial loads.

This mounting ensures good stability of the suspended equipment.

APPLICATIONS

- Metal cutting or metal forming machines (presses, punches, ...).
- Heavy rotating machines.

(1) Natural frequencies with max/min loads, see: OPERATING CHARACTERISTICS.

DIMENSIONS

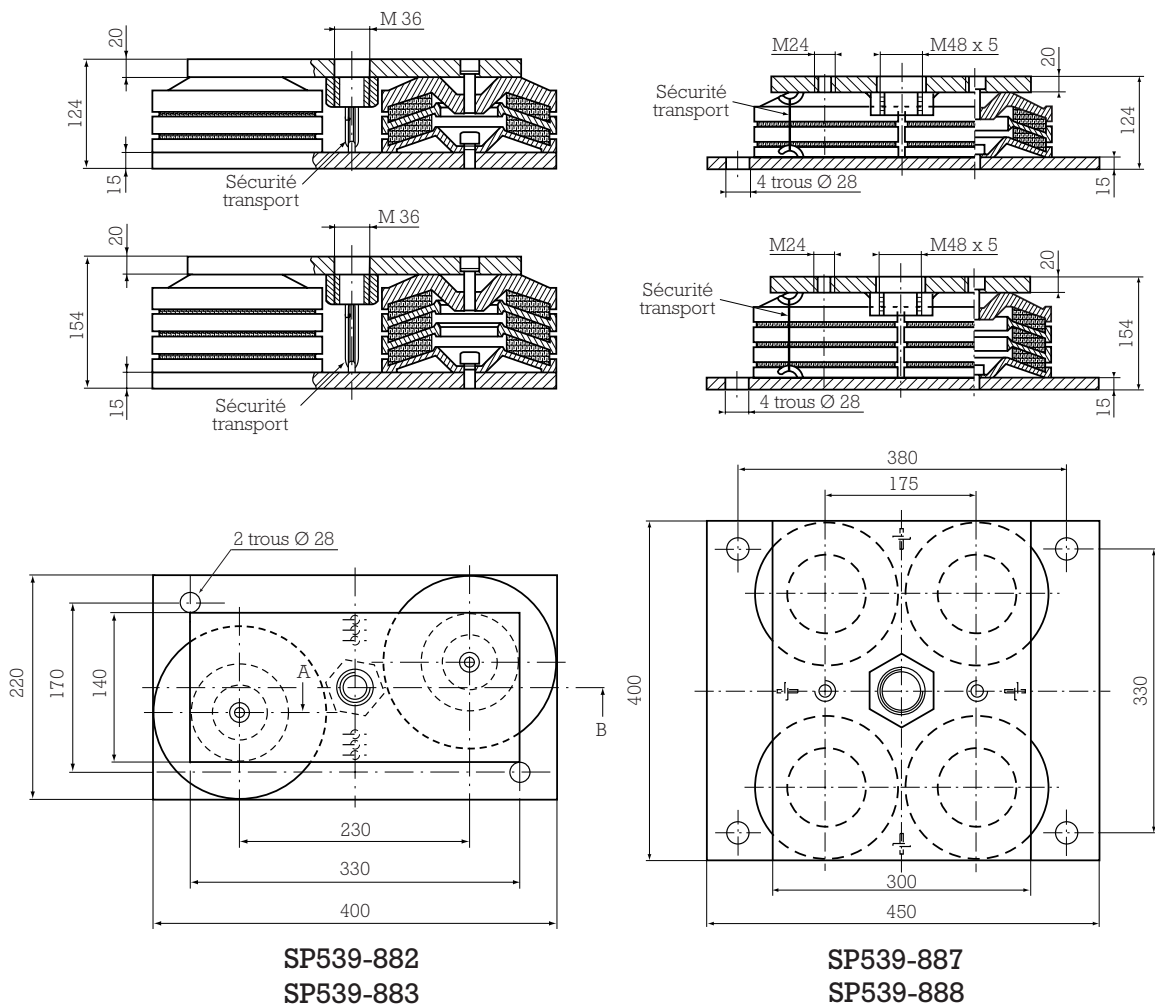

OPERATING CHARACTERISTICS

Reference	Heigh mm	Load range daN	Natural frequency Hz	Weight of mounting kg
SP539-882	124	0.5 to 14	12 to 16	37
SP539-883	154		10 to 13	41
SP539-887	124	1 to 28	12 to 16	70
SP539-888	154		10 to 13	82

1 kg ≈ 1 daN

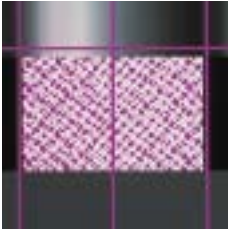

V118-MG V118-DG V318 V318-D



(1) Natural frequency:
11 to 22 Hz

DESCRIPTION

V118-MG and V318 mountings have cast iron cover and base with 4 mounting holes in the base and a central tapped hole in the cover.

The resilient elements are stainless steel wire mesh cushions:

- V118-MG and V318 have two cushions;
- V118-DG and V318-D have three cushions.

APPLICATIONS

This series of mountings have a natural frequency between 18 and 25 Hz and can be used for mounting:

- heavy machinery (grinders, crushers, inclined presses, eccentric presses, printing presses, textile machines).
- rotating machines (motors, generator sets, pumps, etc), which rotate at more than 2000 rpm for V118-DG and V318-D and up to 2500 rpm for V118-MG and V318.
- gantry cranes (structure, cabs, equipment).

The isometric stiffness characteristics and anti-rebound metal cushions of these suspensions makes them suitable for suspending engines on ships, vehicles, etc.

As they can withstand temperatures between - 70°C and + 300°C, they can also be used for mounting exhaust pipes.

(1) Natural frequencies with max/min loads, see: OPERATING CHARACTERISTICS.

DIMENSIONS

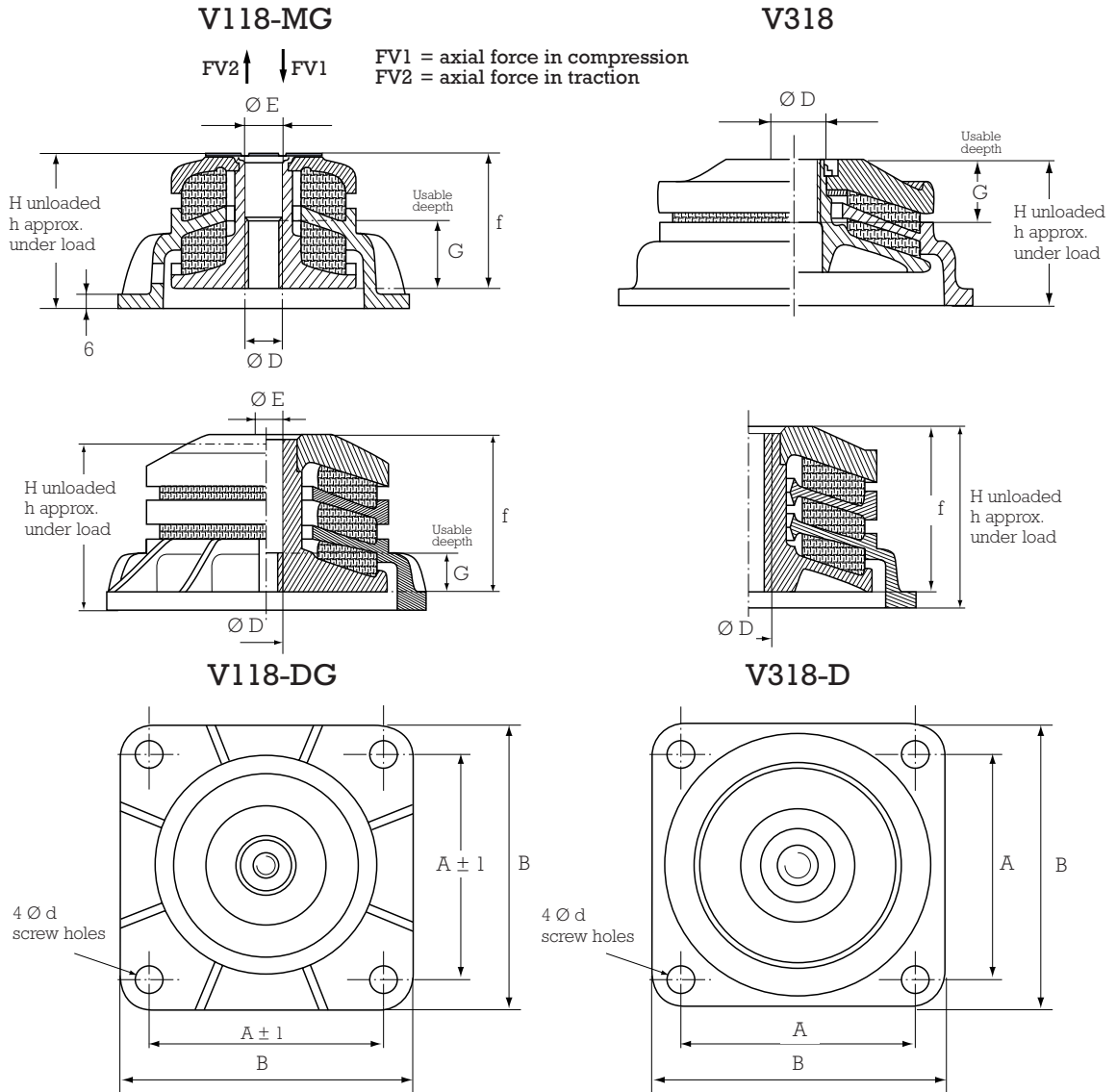

Reference	A mm	B mm	$\varnothing D$	$\varnothing E$ mm	G mm	H mm	$\varnothing d$ mm	f mm	h under FV1 app. mm	h under FV2 app. mm
V118-MG	100	130	M16	16.5	30	73	12	63	68	77
V118-DG	100	130	M16	16.5	30	98	12.5	84	-	-
V 318	170	220	M27	-	59	97	17	-	93	100
V318-D	170	220	M27	-	-	125	17	112	-	-

OPERATING CHARACTERISTICS

- Maximum permitted excitation at natural frequency of suspension: ± 0.3 mm.
- Amplification factor at resonance: < 4 .

Reference	Load range daN	Maximum dynamic forces daN		Natural frequency Hz	Weight of mounting kg
		Axial	Radial		
V118-MG V118-DG	50 to 900	4500	1500	16 to 22 11 to 17	2 2.4
V 318 V318-D	250 to 7000	21000	9000	16 to 22 11 to 17	10 13

1 kg \approx 1 daN

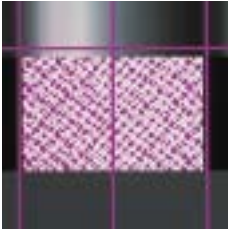

V120 V120-D
V125 V125-D



(1) Natural frequency:
13 to 25 Hz

DESCRIPTION

Series of all metal low profile mounts with one or two cushions, working in compression only, permitting high dynamic overloads (using a load distribution plate). Mounts can be fixed to floor.

Made of cups welded on a steel base with one or two stainless steel cushions (inox 18/8).

The steel parts are painted to protect against corrosion.

APPLICATIONS

These mounts are designed for:

- suspension of presses,
- suspension of machine-tools which do not need levelling,
- suspension of transformers, diesel engines,
- suspension of rotating machines operating:
 - > 2500 rpm: V120 and V125,
 - > 2000 rpm: V120-D and V125-D.

(1) Natural frequencies with max/min loads, see: OPERATING CHARACTERISTICS.

DIMENSIONS

V120
V125

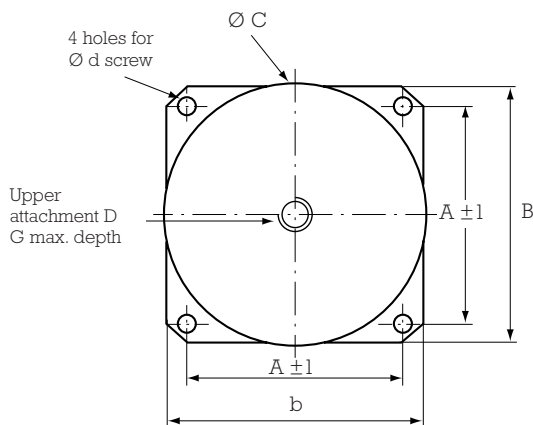
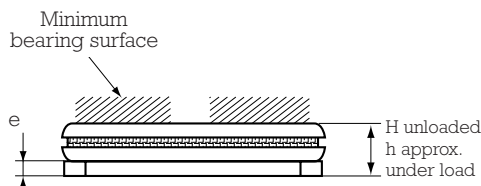

V120-D
V125-D

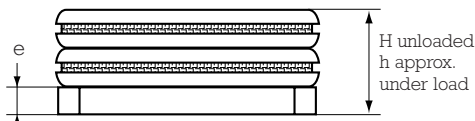

Reference	A mm	B mm	C mm	D	G mm	H mm	b mm	Ø d mm	e mm	h mm
V120	114	150	126	M16	28	36	140	12	8	32
V125	138	165	165	M20						
V120-D	114	150	126	M16	50	70	140	12	16	66
V125-D	138	165	165	M20						

OPERATING CHARACTERISTICS

- Maximum permitted excitation at natural frequency of suspension:
V120 and V125: ± 0.3 mm,
V120-D and V125-D: ± 0.4 mm.
- Natural frequencies for this amplitude:
 - axial } V120 and V125: 15 to 20 Hz,
 - radial } V120-D and V125-D: 13 to 18 Hz.
- Amplification factor at resonance: < 5.
- Operating temperature: - 70°C to + 300°C.

Reference	Static axial load daN	Maximum dynamic force in compression daN	Weight of mounting kg
V120	120 - 2500	12500	2.3
V125	250 - 7000	22500	3.5
V120-D	120 - 2500	12500	4.5
V125-D	250 - 7000	22500	7

1 kg \approx 1 daN



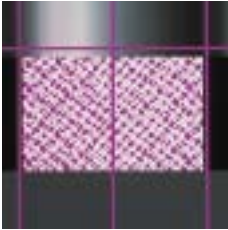

V164 V168



(1) Natural frequency:
8 to 22 Hz

DESCRIPTION

The V164 and V168 dampers have a cover, an AG3 mounting plate and an AU4G shaft. The assembly is chromatised.

The upper and lower stainless steel cushions are the resilient elements of the mounting. It has four $\varnothing 8$ mounting holes on the mounting plate and one M10 tapped hole on upper cover.

APPLICATIONS

The load range of between 5 and 170 kg makes it suitable for isolating light machine tools from motors with rotational speeds of over 2500 rpm.

The V164 has an isometric natural frequency of 15 to 22 Hz and 8 to 12 Hz. Their lower cushion can withstand accidental traction forces (for example, shock rebound).

These dampers are not affected by aggressive chemicals and can be used, for example, for mounting petro-chemical pumps.

(1) Natural frequencies with max/min loads, see: OPERATING CHARACTERISTICS.

DIMENSIONS

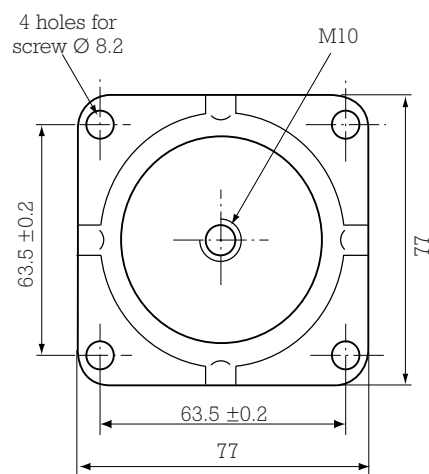
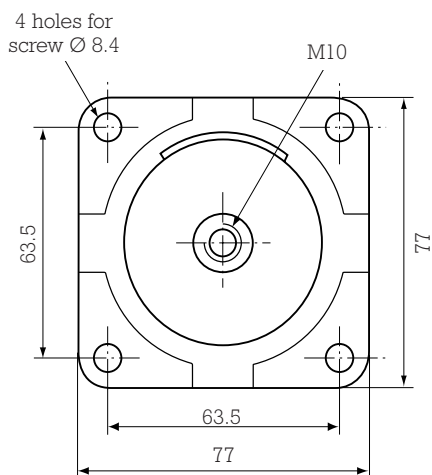
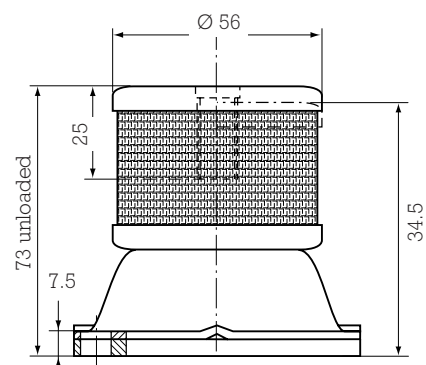
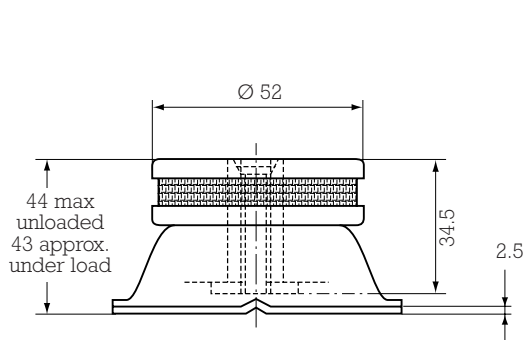

V164

V168

OPERATING CHARACTERISTICS

- Maximum permitted excitation at natural frequency of suspension: ± 0.3 mm.
- Amplification factor at resonance: < 4 .
- Operating temperature: $- 70^{\circ}\text{C}$ to $+ 300^{\circ}\text{C}$.

Reference	Natural frequency axial and radial	Static axial load daN	Maximum dynamic forces (daN)		Weight of mounting kg
			Compression	Traction	
V164-F V164-G	15 to 22 Hz	5 to 30 20 to 120	150 1250	150 600	0.18
V168-1U V168-2U	8 to 12 Hz	25 to 60 50 to 170	180 510	75 150	0.35

1 kg \approx 1 daN

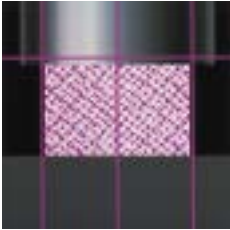

V402-MG



(1) Natural frequency:
15 to 22 Hz

DESCRIPTION

The V402-MG damper has a cast iron upper cover and mounting plate and a high strength aluminium alloy shaft.

The resilient element is a woven stainless steel cushion.

The cast iron parts are painted.

APPLICATIONS

This all metal damper has a natural frequency between 15 and 22 Hz and is isometric within the defined load ranges. It is designed for compression loads but its retaining cushion makes it able to withstand high tensile forces.

The conical cushions provide resilience in all directions. It can be used to suspend fixed or on board machine tools and rotating machines (pumps, engines, generator sets rotating at speeds over 2500 rpm).

(1) Natural frequencies with max/min loads, see: OPERATING CHARACTERISTICS.

DIMENSIONS

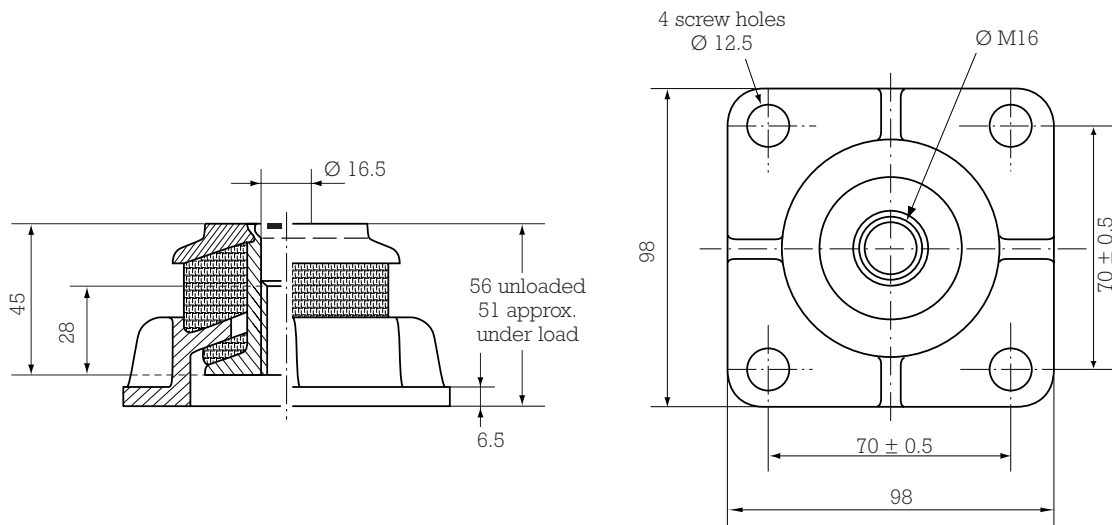

OPERATING CHARACTERISTICS

- Natural frequency:

- axial
 - radial
- } 15 to 22 Hz.

- Maximum permitted excitation at natural frequency of suspension: ± 0.3 mm.
- Amplification factor at resonance: < 4 .
- Operating temperature: -70°C to $+300^{\circ}\text{C}$.
- Weight 0.75 Kg approximative.

Reference	Static load in daN	Maximum dynamic force in daN (compression or traction)
V402-MG	30 to 700	3500

1 kg \approx 1 daN

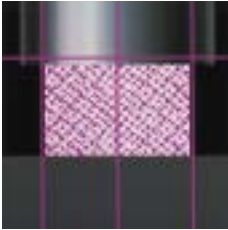

V1H751

V1H752



(1) Natural frequency:
15 to 25 Hz

DESCRIPTION

The V1H751 and 752 range has a pressed steel casing and mounting plate and light alloy shaft. The resilient element is a stainless steel wire pad.

The steel parts are painted.

APPLICATIONS

The V1H 751 and 752 have a natural frequency between 15 and 25 Hz for static loads under compression.

The -11 and -12 versions are reinforced by radial cushions and can absorb considerable horizontal dynamic forces, which makes it possible to use them for mounting on board equipment in ships, rail, road transport, civil engineering plant (engines, pumps, generator sets, pipework) or fixed machines that have to be floor mounted.

(1) Natural frequencies with max/min loads, see: OPERATING CHARACTERISTICS.

DIMENSIONS

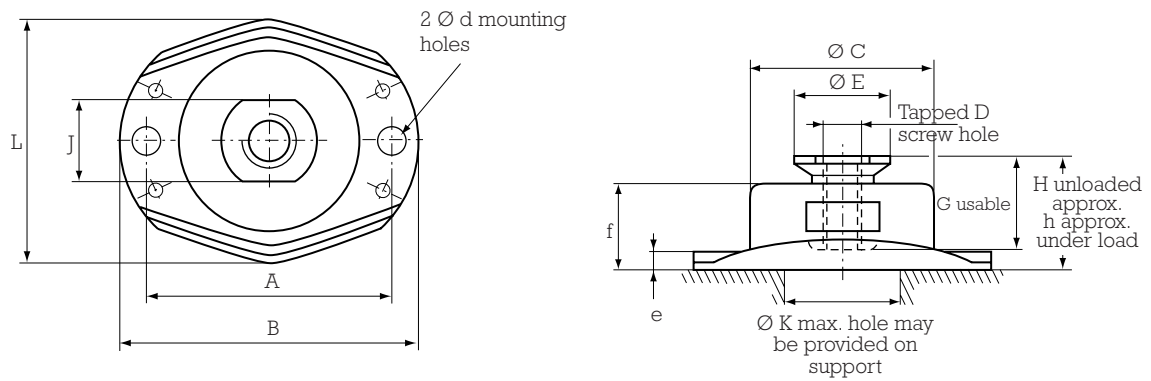

Reference	A mm	B mm	Ø C mm	D	Ø E mm	G mm	H mm	J mm	Ø K mm	L mm	Ø d mm	e mm	f mm	h mm
V1H751	92 *	110	69	M12	32	47	54	27	40	90	11*	5.5	40.5	50
V1H752	126	152	96	M20	41	51	60	36	60	124	15	7	45	56

* Oblong holes with 2 mm aperture.

OPERATING CHARACTERISTICS

- Natural frequency:

- axial
 - radial
- } 15 to 25 Hz depending on load.

- Maximum permitted excitation at natural frequency of suspension: ± 0.4 mm.

- Amplification factor at resonance: < 4 .

- Structural strength corresponding to continuous acceleration under compression of 5 g for the 751 and 10 g for the 752 with maximum load.

- Operating temperature: $- 70^{\circ}\text{C}$ to $+ 300^{\circ}\text{C}$.

- Weight V1H751: 0.75 kg,
V1H752: 1.6 kg.

Reference	Static axial load daN	Maximum dynamic force daN			Upper mounting screws		
		Compression	Traction	Radial	Take up length mm		Torque N.m
					min.	max.	
V1H751-01	70 - 250	900	900	300	25	45	18
V1H751-11	70 - 250	900	900	800			40
V1H751-02	150 - 500	2000	1800	650			18
V1H751-12	150 - 500	2000	1800	1600			40
V1H752-01	300 - 1000	4000	3000	1000	35	50	50
V1H752-11	300 - 1000	4000	3000	3000			140

1 kg \approx 1 daN

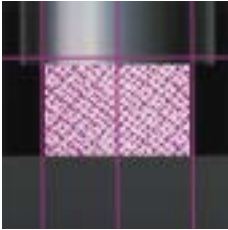

V1H5023 V1H5025



(1) Natural frequency:
15 to 25 Hz

DESCRIPTION

The V1H5023 and V1H5025 mountings have cast iron upper housing and base. The base has four fixing holes.

The resilient elements are stainless steel wire mesh cushions. The cast iron parts are painted.

APPLICATIONS

Isolation of machine-tools: grinding machines, crushing machines, fly-presses, printing machines, textile machinery, etc.

Isolation of rotating machines: engines, sets, pumps, etc. rotating over 2500 rpm.

Marine: isolation of exhaust pipes, manifold, boilers, motors, sets, pumps, etc.

(1) Natural frequencies with max/min loads, see: OPERATING CHARACTERISTICS.

DIMENSIONS

FV1 = axial force in compression
 FV2 = axial force in traction
 FH = radial force

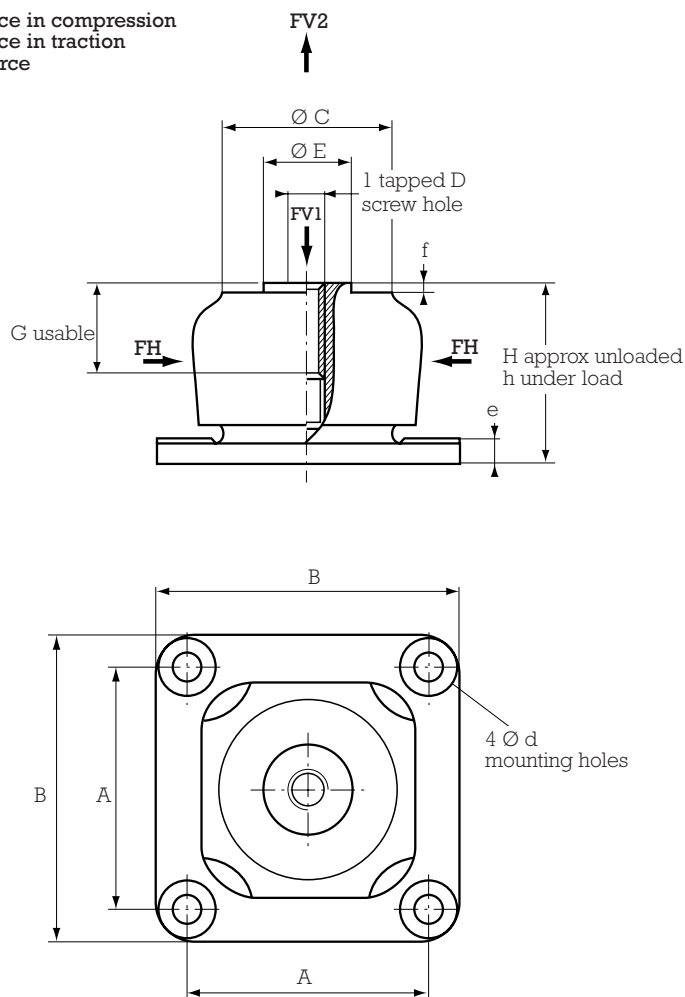

Reference	A mm	B mm	Ø C mm	D	Ø E mm	G mm	H mm	Ø d mm	e mm	f mm	h under FV1 mm	h under FV2 mm
V1H5025 *	138	172	100	M20	50	50	100	15	12	5	96	104
V1H5023 *	215	260	140	M33	70	60	136	23	18	7	132	140

* Load indice, see below.

OPERATING CHARACTERISTICS

- Maximum permitted excitation at natural frequency of suspension: ± 0.3 mm.
- Natural frequencies for this amplitude:
 - axial } 15 to 25 Hz depending on load.
 - radial }
- Amplification factor at resonance: < 4 .
- Structural strength: see table.
- Operating temperature: -70°C to $+300^{\circ}\text{C}$.

Reference	Static axial load daN	Maximum dynamic force (daN)			Weight kg
		Axial compression	Axial traction	Radial	
V1H5025-01	350 - 900	4500	4500	4500	6.7
V1H5025-02	800 - 3000	15000	4500	4500	
V1H5023-01	1000 - 2500	12500	12500	12500	24.4
V1H5023-02	2000 - 7000	35000	12500	12500	

1 kg \approx 1 daN



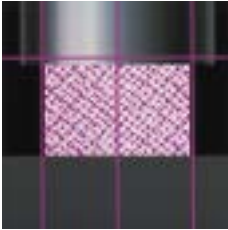

V1H-6000

V1H-6100



(1) Natural frequency:
12 to 18 Hz

DESCRIPTION

The V1H-6000 and V1H-6100 mountings steel have a mounting plate, a cover and a swaged steel shaft.

They are available with stainless steel or mild steel zinc plated metalwork.

The resilient parts are stainless steel wire cushions.

The steel parts are zinc plated.

APPLICATIONS

The V1H-6000 and V1H-6100 mountings have a natural frequency of between 12 and 18 Hz and are designed for suspending rotating machines, electronic cabinets, pipes, air conditioning systems, etc. Its all metal construction means that its characteristics do not deteriorate with time and it maintains its height under load, even in the most severe ambient conditions and temperatures.

The shape of the armature and upper cushion provide high radial performance and a structural strength of 3 g, making it suitable for mounting on board equipment on military ground vehicles and ships.

(1) Natural frequencies with max/min loads, see: OPERATING CHARACTERISTICS.

DIMENSIONS

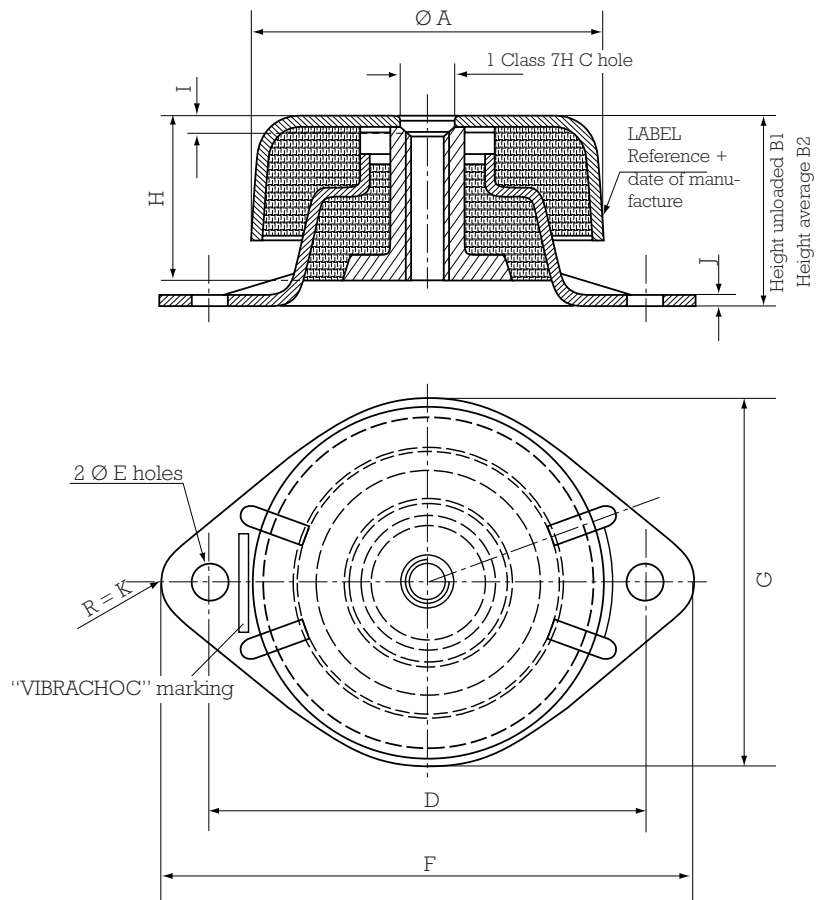

Reference	Ø A mm	B1 mm	B2 mm	C	D mm	Ø E mm	F mm	Ø G mm	H mm	I mm	J mm	K mm
V1H-6000 *	105	62	57	M12	130	11	160	110	50	5	3	15
V1H-6100 *	82	56	51	M10	98	9	120	85	46	3	2	11

* load indice, see below.

OPERATING CHARACTERISTICS

- Natural frequency:
 - axial
 - radial
 } 12 to 18 Hz depending on the load.
- Structural strength: 3 g.
- Complies with GAMA13-MIL.STD. 167-1.
- Operating temperature: - 70°C to + 300°C.
- Amplification factor at resonance: < 4.

Steel reference	Inox reference	Load range daN	Weight kg
V1H-6100-01	V1H-6100-01NX	25 to 75	0.65
V1H-6100-02	V1H-6100-02NX	50 to 150	
V1H-6100-03	V1H-6100-03NX	100 to 250	
V1H-6000-21	V1H-6000-21NX	30 to 75	1.6
V1H-6000-01	V1H-6000-01NX	50 to 150	
V1H-6000-02	V1H-6000-02NX	100 to 300	
V1H-6000-03	V1H-6000-03NX	200 to 500	

1 kg ≈ 1 daN

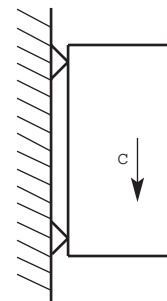

Mountings with radial load
(CONSULT US)

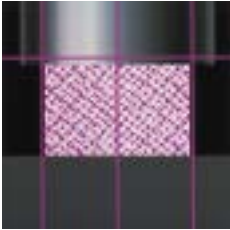

V1B1114 V1B1134
V1B1115 V1B1135
V1B1116 V1B1136



(1) Natural frequency:
3 to 9 Hz

DESCRIPTION

This range of mountings has one or two steel mounting plates depending on the model, one or several high strength steel springs, 2 light alloy rings and a stainless steel wire cushion in each spring.

All steel parts are painted.

APPLICATIONS

These very low frequency isolators (down to 3 Hz) can be used to mount machine rotating at speeds over 450 rpm, vibrators and impact machines, achieving an attenuation of about 95%.

They are all metal and can be used outdoors or in the harshest conditions.

As they do not creep, their life time may be the same as that of the machine they are used to mount.

A metal cushion inside each spring increases the damping factor and limits the amplification at the natural frequency.

(1) Natural frequencies with max/min loads, see: OPERATING CHARACTERISTICS.

DIMENSIONS

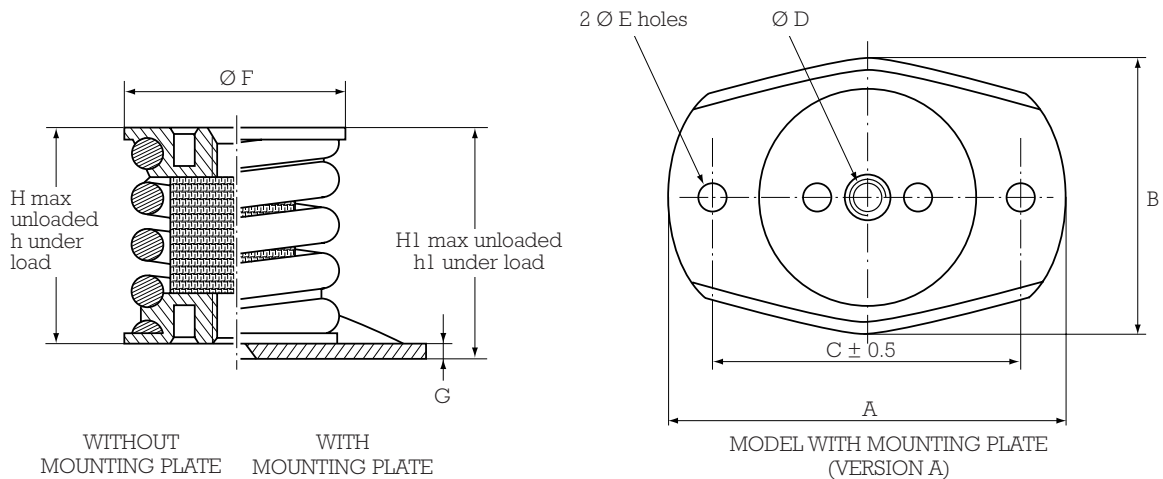

Reference	A mm	B mm	C mm	Ø D	Ø E mm	Ø F mm	G mm	H mm	h mm	Hl mm	hl mm
V1B1114	90	60	69.6	M8	7	47	2.5	59	47.5	61.5	50 ±2
V1B1115	90	60	69.6	M8	7	47	2.5	59	47.5	61.5	50 ±3
V1B1116	90	60	69.6	M8	7	47	2.5	88	68	90.5	70.5 ±5
V1B1134	140	100	110	M12	11	78	4	88	78	92	82 ±2
V1B1135	140	100	110	M12	11	78	4	88	78	92	82 ±3
V1B1136	140	100	110	M12	11	78	4	142	120	146	124 ±5

OPERATING CHARACTERISTICS

• Vibrational and mechanical characteristics

Isolation of rotating machines with a minimum speed of:

Rpm	Series	Axial natural frequency = fz	Radial natural frequency = fr	Axial max. force	Radial max. force	Amplification factor at resonance
1000	V1B1114 & V1B1134	7 to 9 Hz	fr = fz	4 g	1.2 g	≤ 5
650	V1B1115 & V1B1135	5 to 6 Hz	fr = fz	2 g	1.2 g	≤ 10
450	V1B1116 & V1B1136	3 to 4 Hz	fr = 0.7 fz	2 g	0.5 g	≤ 10

Maximum permitted excitation at natural frequency of suspension: ± 1 mm.

• Load ranges

Part number		Static load daN
without mounting plate	with mounting plate	
V1B1114-01	V1B1114-01A	6 to 10.5
V1B1114-02	V1B1114-02A	7.5 to 13.5
V1B1114-03	V1B1114-03A	12 to 20
V1B1114-04	V1B1114-04A	18 to 30
V1B1114-05	V1B1114-05A	24 to 46
V1B1114-06	V1B1114-06A	40 to 75
V1B1115-01	V1B1115-01A	5 to 7
V1B1115-02	V1B1115-02A	6 to 9
V1B1115-03	V1B1115-03A	9 to 14
V1B1115-04	V1B1115-04A	14 to 20
V1B1115-05	V1B1115-05A	20 to 30
V1B1115-06	V1B1115-06A	30 to 50
V1B1116-01	V1B1116-01A	5 to 7
V1B1116-02	V1B1116-02A	6 to 9
V1B1116-03	V1B1116-03A	9 to 14
V1B1116-04	V1B1116-04A	14 to 20
V1B1116-05	V1B1116-05A	20 to 30
V1B1116-06	V1B1116-06A	30 to 50

Part number		Static load daN
without mounting plate	with mounting plate	
V1B1134-01	V1B1134-01A	40 to 85
V1B1134-02	V1B1134-02A	65 to 125
V1B1134-03	V1B1134-03A	110 to 190
V1B1134-04	V1B1134-04A	175 to 270
V1B1134-05	V1B1134-05A	250 to 400
V1B1134-06	V1B1134-06A	360 to 560
V1B1134-07	V1B1134-07A	540 to 730
V1B1135-01	V1B1135-01A	30 to 48
V1B1135-02	V1B1135-02A	48 to 80
V1B1135-03	V1B1135-03A	80 to 130
V1B1135-04	V1B1135-04A	130 to 200
V1B1135-05	V1B1135-05A	200 to 310
V1B1135-06	V1B1135-06A	310 to 400
V1B1135-07	V1B1135-07A	420 to 560
V1B1136-01	V1B1136-01A	75 to 105
V1B1136-02	V1B1136-02A	95 to 130
V1B1136-03	V1B1136-03A	115 to 160
V1B1136-04	V1B1136-04A	160 to 230
V1B1136-05	V1B1136-05A	220 to 310
V1B1136-06	V1B1136-06A	300 to 415
V1B1136-07	V1B1136-07A	410 to 550

1 kg ≈ 1 daN

MULTIPLE ELEMENTS

DIMENSIONS

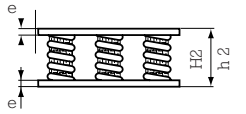
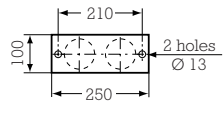
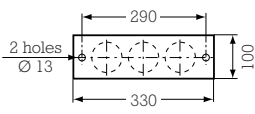
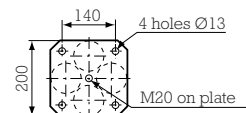
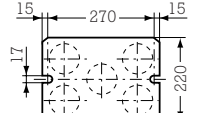
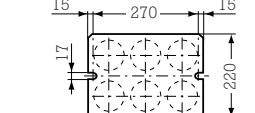
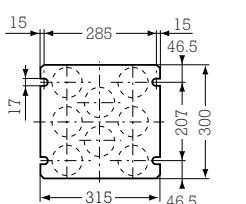
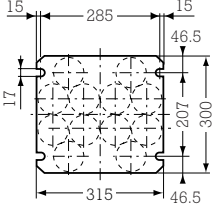
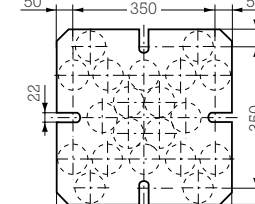
 <p>H2 max unload - h2 under load</p>	 <p>V1B1134-25, -26 or -27 V1B1135-25, -26 or -27 V1B1136-25, -26 or -27</p>	 <p>V1B1134-36 or -37 V1B1135-36 or -37 V1B1136-36 or -37</p>
 <p>V1B1134-45, -46 or -47 V1B1135-45, -46 or -47 V1B1136-45, -46 or -47</p>	 <p>V1B1134-56 or -57 V1B1135-56 or -57 V1B1136-56 or -57</p>	 <p>V1B1134-66 or -67 V1B1135-66 or -67 V1B1136-66 or -67</p>
 <p>V1B1134-86 or -87 V1B1135-86 or -87 V1B1136-86 or -87</p>	 <p>V1B1134-125, -126 or -127 V1B1135-125, -126 or -127 V1B1136-125, -126 or -127</p>	 <p>V1B1134-205, -206 or -207 V1B1135-205, -206 or -207 V1B1136-205, -206 or -207</p>

OPERATING CHARACTERISTICS

- **Vibrational and mechanical characteristics** (see Single elements)
- **Load ranges**

Part number	Static load daN	H2 unload. mm	h2 under load mm	e mm	Part number	Static load daN	H2 unload. mm	h2 under load mm	e mm
V1B1134-25	500 to 800	96	86 ± 3	4	V1B1135-66	1860 to 2520	108	98 ± 3	10
V1B1134-26	720 to 1120	96	86 ± 3	4	V1B1135-67	2520 to 3360	110	98 ± 3	10
V1B1134-27	1080 to 1460	106	94 ± 3	8	V1B1135-86	2480 to 3360	108	98 ± 3	10
V1B1134-36	1080 to 1680	106	94 ± 3	8	V1B1135-87	3360 to 4480	110	98 ± 3	10
V1B1134-37	1620 to 2190	106	94 ± 3	8	V1B1135-125	2340 to 3720	108	98 ± 3	10
V1B1134-45	1000 to 1600	104	94 ± 3	8	V1B1135-126	3720 to 5040	108	98 ± 3	10
V1B1134-46	1440 to 2240	104	94 ± 3	8	V1B1135-127	5040 to 6720	110	98 ± 3	10
V1B1134-47	2160 to 2920	106	94 ± 3	8	V1B1135-205	3900 to 6200	108	98 ± 3	10
V1B1134-56	1800 to 2800	108	98 ± 3	10	V1B1135-206	6200 to 8400	108	98 ± 3	10
V1B1134-57	2700 to 3650	110	98 ± 3	10	V1B1135-207	8400 to 11200	110	98 ± 3	10
V1B1134-66	2160 to 3360	108	98 ± 3	10	V1B1136-25	440 to 620	148	128 ± 5	4
V1B1134-67	3240 to 4380	110	98 ± 3	10	V1B1136-26	600 to 830	148	128 ± 5	4
V1B1134-86	2880 to 4480	108	98 ± 3	10	V1B1136-27	820 to 1100	158	136 ± 5	8
V1B1134-87	4320 to 5840	110	98 ± 3	10	V1B1136-36	900 to 1260	158	136 ± 5	8
V1B1134-125	3000 to 4800	108	98 ± 3	10	V1B1136-37	1230 to 1650	158	136 ± 5	8
V1B1134-126	4300 to 6720	108	98 ± 3	10	V1B1136-45	880 to 1280	156	136 ± 5	8
V1B1134-127	6480 to 8760	110	98 ± 3	10	V1B1136-46	1200 to 1660	156	136 ± 5	8
V1B1134-205	5000 to 8000	108	98 ± 3	10	V1B1136-47	1640 to 2200	158	136 ± 5	8
V1B1134-206	7200 to 11200	108	98 ± 3	10	V1B1136-56	1500 to 2075	160	140 ± 5	10
V1B1134-207	10800 to 14600	110	98 ± 3	10	V1B1136-57	2050 to 2750	162	140 ± 5	10
V1B1135-25	390 to 620	96	86 ± 3	4	V1B1136-66	1800 to 2490	160	140 ± 5	10
V1B1135-26	620 to 840	96	86 ± 3	4	V1B1136-67	2460 to 3300	162	140 ± 5	10
V1B1135-27	840 to 1120	106	94 ± 3	8	V1B1136-86	2400 to 3320	160	140 ± 5	10
V1B1135-36	930 to 1260	106	94 ± 3	8	V1B1136-87	3280 to 4400	162	140 ± 5	10
V1B1135-37	1260 to 1680	106	94 ± 3	8	V1B1136-125	2640 to 3720	160	140 ± 5	10
V1B1135-45	780 to 1240	104	94 ± 3	8	V1B1136-126	3600 to 4980	160	140 ± 5	10
V1B1135-46	1240 to 1680	104	94 ± 3	8	V1B1136-127	4920 to 6600	162	140 ± 5	10
V1B1135-47	1680 to 2240	106	94 ± 3	8	V1B1136-205	4400 to 6200	160	140 ± 5	10
V1B1135-56	1550 to 2100	108	98 ± 3	10	V1B1136-206	6000 to 8300	160	140 ± 5	10
V1B1135-57	2100 to 2800	110	98 ± 3	10	V1B1136-207	8200 to 11000	162	140 ± 5	10

1 kg ≈ 1 daN



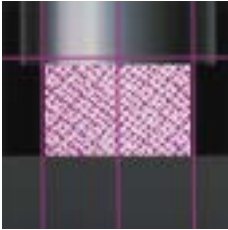

7002



- (1) Natural frequency:
- axial 7 to 10 Hz
 - radial 4.5 to 6 Hz

DESCRIPTION

The 7002 damper has a satin finish treated AG3 casing and mounting plate, a stainless steel centre axis. A spring and stainless steel cushion provide the resilient elements. It has four $\varnothing 5.2$ mounting holes in the base and a tapped hole in the centre axis.

APPLICATIONS

Its axial natural frequency of between 7 and 10 Hz and its integral travel limiter enable 7002 dampers to be used for mounting electronic or computer equipment, navigation equipment and on board measurement instruments.

They can also be used for static equipment for suspending control panels, etc.

Their all metal construction enable them to operate in the harshest of conditions.

(1) Natural frequencies with max/min loads, see: OPERATING CHARACTERISTICS.

DIMENSIONS

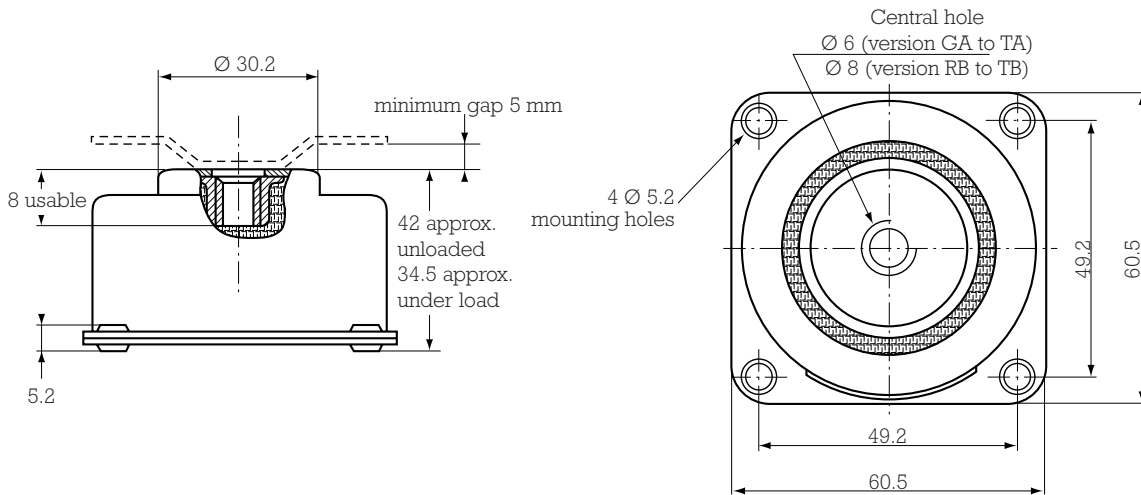

OPERATING CHARACTERISTICS

- Natural frequencies:
 - axial: 7 to 10 Hz depending on load,
 - radial: 4.5 to 6 Hz depending on load.
- Maximum permitted excitation at natural frequency of suspension: ± 0.75 mm.
- Amplification factor at resonance: < 4 .
- Operating temperature: $- 70^{\circ}\text{C}$ to $+ 300^{\circ}\text{C}$.
- Structural strength corresponds to continuous acceleration of 10 g with maximum load.
- Travel available under shock:
 - axial: ± 6 mm,
 - radial: ± 5 mm.
- Weight: 100 to 200 (depending on version).

Reference	Axial static load daN	Central hole
7002 GA	0.70 - 1.25	M6
7002 HA	1.15 - 2.30	
7002 JA	2.00 - 4.50	
7002 KA	2.80 - 5.60	
7002 LA	4.50 - 9.00	
7002 UA	7.00 - 14.00	
7002 MA	8.00 - 18.00	
7002 PA	16.00 - 22.00	
7002 RB	20.00 - 33.00	M8
7002 SB	28.00 - 45.00	
7002 TB	40.00 - 60.00	

1 kg \approx 1 daN

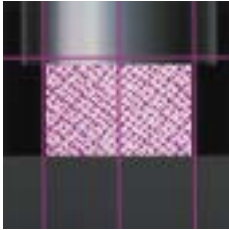

VE101 VE111
VE112 VE113

(1) Natural frequency:
3.5 to 6 Hz

See also
PAULSTRA
elastomer range:
Traxiflex



DESCRIPTION

VE isolators have a cylindrical stainless steel spring, a galvanised body, an elastomer noise reduction guide and steel rings or studs depending on the model. The VE112 series has a steel cushion inside the spring.

APPLICATIONS

These isolators with a natural frequency of between 3.5 and 6 Hz are specially designed for suspending false ceilings, air conditioning equipment and pipework and significantly reduces noise in buildings.

(1) Natural frequencies with max/min loads, see: OPERATING CHARACTERISTICS.

DIMENSIONS

VE101

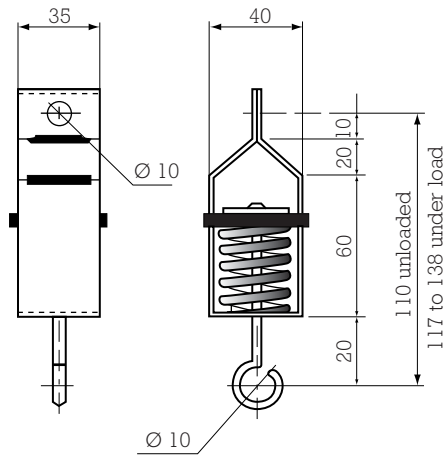

VE111

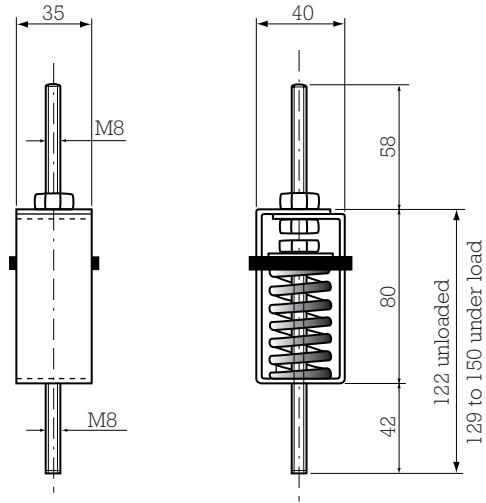

VE112

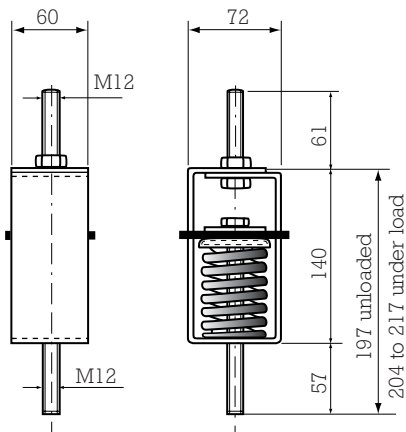

VE113

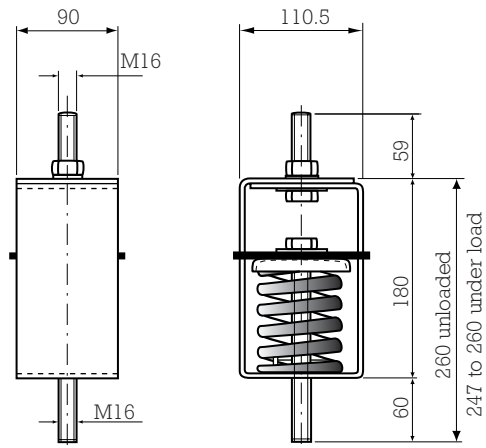

OPERATING CHARACTERISTICS

Reference	Static load in daN
VE101 - 01	1 to 5
VE101 - 02	4 to 13
VE101 - 03	7 to 20
VE101 - 04	12 to 33
VE101 - 05	19 to 43

Reference	Static load in daN
VE112 - 01	25 to 70
VE112 - 02	45 to 130
VE112 - 03	85 to 230

Reference	Static load in daN
VE111 - 01	1 to 5
VE111 - 02	4 to 13
VE111 - 03	7 to 20
VE111 - 04	12 to 33
VE111 - 05	19 to 43

Reference	Static load in daN
VE113	150 to 420

1 kg ≈ 1 daN

Vibration characteristics:

- Natural frequency: 3.5 to 6 Hz.

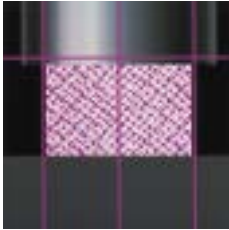

VIBCABLE



- (1) Natural frequency:
5 to 25 Hz

DESCRIPTION

This range of mountings has a stainless steel cable wound between light alloy bars. The 8010 to 8060 versions are assembled using stainless steel clips and the 8080 to 8140 models have galvanised steel screws.

There are two or four mounting holes, by bar, smooth, counter sunk or tapped.

APPLICATIONS

With a natural frequency between 5 and 25 Hz, damping up to 40% and high deflection in all directions, these dampers can absorb accelerations to equipment subjected to shock or drop.

Protection of equipment in containers, protection of racks and any fragile on board equipment.

(1) Natural frequencies with max/min loads, see: OPERATING CHARACTERISTICS.

DIMENSIONS

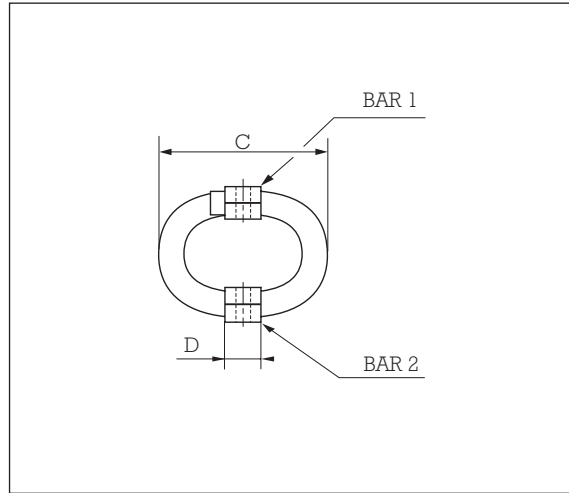
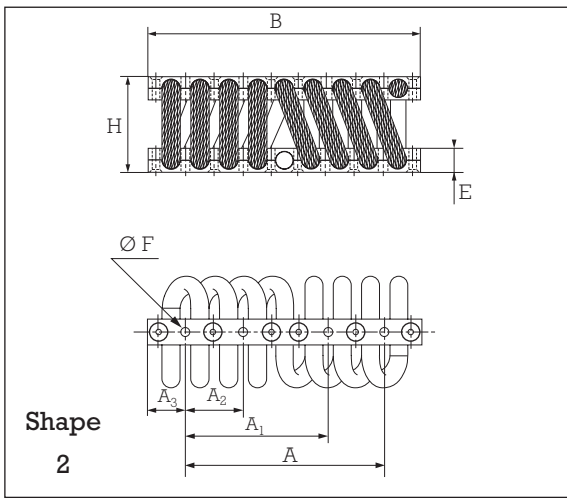
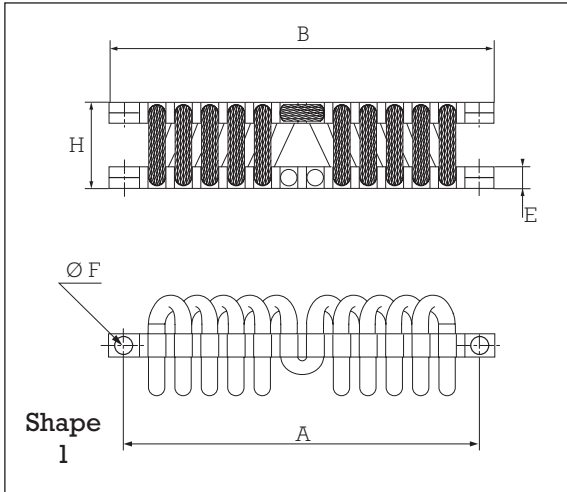

Reference	Shape	A mm	B mm	C (mm) depending on version		D mm	E mm	F mm (2 fixing holes)		H (mm) depending on version					
				min.	max.			tapped	threaded	01	02	03	04	05	06
V3CA8010-01 to -06	1	68	82	25	38	10	5	4	M4	18	26	20	28	30	33
V3CA8020-01 to -06	1	100	112	29	43	12.5	6	5	M5	21	31	35	25	28	38
V3CA8030-01 to -06	1	114	127	37	49	14	8	6	M6	28	30	33	36	38	41
V3CA8040-01 to -03	1	114	127	37	44	14	8	6	M6	28	33	38	-	-	-
V3CA8060-01 to -06	2	114	127	37	95	14	10	6	M6	38	43	87	43	31	34
V3CA8080-01 to -06	2	131	146	57	102	16	13	6	M6	48	54	60	64	80	90

Reference	Shape	A mm	A ₁ mm	A ₂ mm	A ₃ mm	B mm	C (mm) depending on version		D mm	E mm	F mm (4 fix. holes)		H (mm) depending on version					
							min.	max.			tapped	thread.	01	02	03	04	05	06
V3CA8090-01 to -06	2	156	111	44.5	30	216	80	135	25	16	8	M8	70	74	89	110	68	77
V3CA8100-01 to -06	2	156	111	44.5	30	216	92	150	25	20	8	M8	75	89	95	110	83	108
V3CA8110-01 to -06	2	191	136.5	54.5	38.1	267	102	170	25	25	10	M10	90	95	100	110	-	-
V3CA8120-01 to -04	2	266.5	190.5	76	50.5	370	140	195	40	40	12	M12	132	150	160	160	-	-
V3CA8140-01 to -02	2	378	270	108	70.8	520	224	248	50	50	18	M18	180	218	-	-	-	-

OPERATING CHARACTERISTICS

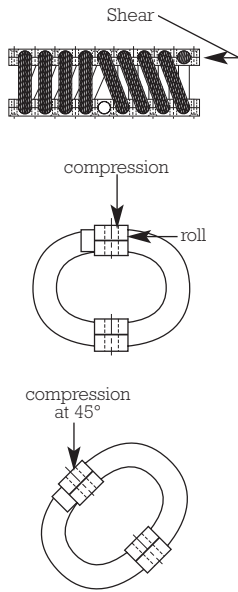

Reference	Static load range in daN																	
	Compression						Compression at 45°						Roll/Shear					
Version	01	02	03	04	05	06	01	02	03	04	05	06	01	02	03	04	05	06
V3CA8010-01 to -06	5	2.5	4	2	1.8	1.5	3.5	2	3	1.8	1.5	1.4	3	1	2.5	0.9	0.7	1
V3CA8020-01 to -06	10	5	5	10	10	6	10	5	4	8.5	7	4	7.5	2.5	3	6	5	3
V3CA8030-01 to -06	20	20	20	15	15	12	18	15	14	10	10	10	10	10	10	8	7	7
V3CA8040-01 to -03	20	20	15	-	-	-	20	15	10	-	-	-	10	10	7.5	-	-	-
V3CA8060-01 to -06	60	50	15	40	80	80	50	30	12	30	60	50	30	20	5	20	40	40
V3CA8080-01 to -06	75	75	50	40	25	25	50	50	35	30	15	14	25	25	20	15	12	10
V3CA8090-01 to -06	100	75	50	50	100	100	100	75	50	35	100	75	50	30	30	25	50	50
V3CA8100-01 to -06	200	150	100	50	200	70	200	150	100	50	150	50	120	75	70	40	100	40
V3CA8110-01 to -06	400	350	300	300	180	100	300	200	300	250	180	75	250	200	200	180	100	50
V3CA8120-01 to -04	600	500	400	400	-	-	600	500	400	400	-	-	500	500	400	400	-	-
V3CA8140-01 to -02	1200	1200	-	-	-	-	1200	900	-	-	-	-	700	700	-	-	-	-

1 kg ≈ 1 daN

- Operating temperature:

- 180°C to + 300°C.

- Electrical resistance:

with conducting coating < 210° Ω.

- Environment:

The material used are unaffected by harsh environments.

- Vibration transmission coefficient curves:

For perfectly free system.

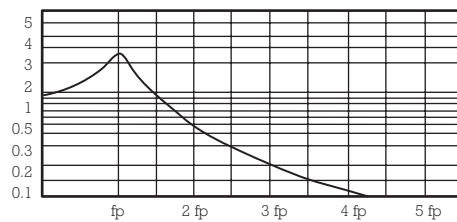

The bars can be supplied with smooth, threaded or countersunk holes. Several combinations are possible:

		Bar 1		
		Smooth holes: L	Threaded holes: N	Countersunk holes: F
Bar 2	Smooth holes: L	LL	NL	FL
	Threaded holes: N	LN	NN	FN
	Countersunk holes: F	LF	NF	FF

- Codification example: V3CA8010-01 LL



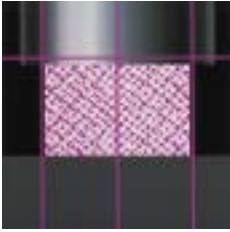

OTHER METAL SUSPENSIONS

MV801 MV803

DESCRIPTION

MV801 and MV803 has a stainless steel wire mesh cushion and spring attached to aluminium alloy upper and lower cup with threaded centre holes.

APPLICATIONS

Isolation of low speed stationary rotating machines (fans, electric motors, pumps ...) sensitive equipments (measuring instruments, laboratory equipment ...).

OPERATING CHARACTERISTICS

Reference	Axial static load daN
MV801-1CC	0.15 - 0.20
MV801-2CC	0.20 - 0.25
MV801-3CC	0.25 - 0.30
MV801-4CC	0.30 - 0.40
MV801-5CC	0.40 - 0.50
MV801-6CC	0.50 - 0.65
MV801-7CC	0.60 - 0.80
MV801-8CC	0.75 - 1.00
MV801-9CC	0.95 - 1.20
MV801-10CC	1.20 - 1.65
MV801-11CC	1.50 - 2.00
MV801-12CC	1.80 - 2.50
MV801-13CC	2.40 - 3.20
MV803-1CC	1.20 - 1.65
MV803-2CC	1.50 - 2.00
MV803-3CC	1.80 - 2.50
MV803-4CC	2.40 - 3.20
MV803-5CC	3.00 - 4.00
MV803-6CC	3.70 - 5.00
MV803-7CC	4.80 - 6.50
MV803-8CC	6.00 - 8.00
MV803-9CC	7.50 - 10.00
MV803-10CC	9.50 - 13.00
MV803-11CC	12.00 - 16.50
MV803-12CC	15.00 - 20.00
MV803-13CC	18.00 - 25.00

1 kg \approx 1 daN

- Natural frequencies:

- axial
 - radial
- } 5 to 10 Hz depending on load.

- Amplification factor at resonance < 5.
- Structural strength corresponds to continuous acceleration of 2 g with maximum load.
- Operating temperature: - 70°C to + 300°C.
- Maximum permitted excitation at natural frequency of suspension:
MV801: ± 0.7 mm.
MV803: ± 1 mm.

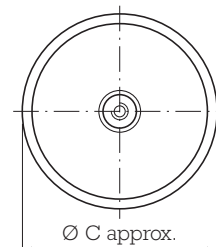
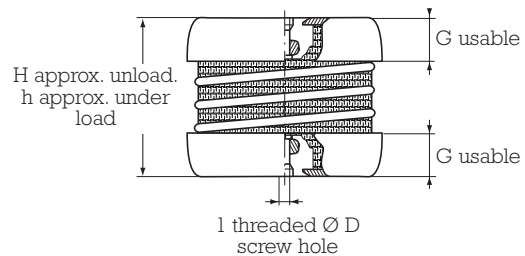

Reference	H mm	Ø C mm	Ø D	G mm	h mm
MV801	42	26	M4	6	25
MV803	55	40.2	M5	8	34



V1N303 V1N304 V1N305 V1N306 V1N308

DESCRIPTION

A single acting telescopic anti-vibration manufactured with a helicoil spring and stainless steel woven cushion.
Protection, paint.

APPLICATIONS

Isolation of exhaust sticking and pipework.

OPERATING CHARACTERISTICS

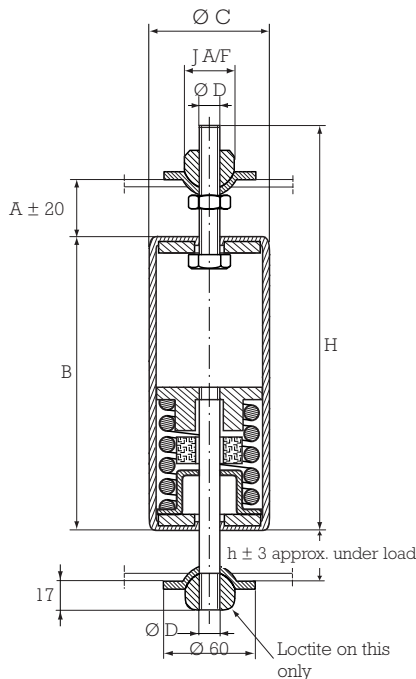

- Maximum permitted excitation at natural frequency of suspension: ± 1 mm.
- Natural frequencies for this amplitude:
 - axial: 3.5 to 5 Hz depending on load.
- Structural strength corresponds to continuous acceleration of 3 g with maximum load.
- Operating temperature: $- 70^{\circ}\text{C}$ to $+ 150^{\circ}\text{C}$.
- Displacement in all directions: ± 40 mm.
- Adjustment between attachment points: ± 20 mm.

Reference	Static load in traction daN	Ø of pipes 3 m long (for information only)
V1N303	45 - 85	150 - 300
V1N304	75 - 140	300 - 500
V1N305	120 - 230	500 - 800
V1N306	200 - 380	800 - 1000
V1N308	270 - 500	1000 - 1200

1 kg \approx 1 daN

Reference	A mm	B mm	Ø C mm	Ø D	H mm	J mm	K mm	h mm
V1N303	40	135	63	M12	210	30	6	35
V1N304	40	155	63	M12	230	30	6	35
V1N305	45	175	82	M16	257	30	8	40
V1N306	45	200	82	M16	282	30	8	40
V1N308	45	220	82	M16	302	30	8	40

V1209

DESCRIPTION

Part of a series of very low frequency isolators working in compression only, giving very efficient isolation for rotating machines running at 250 rpm and above.

APPLICATIONS

Rotating machines, hoppers and sensitive equipment with or without the use of inertia blocks.

OPERATING CHARACTERISTICS

TYPE A TYPE B

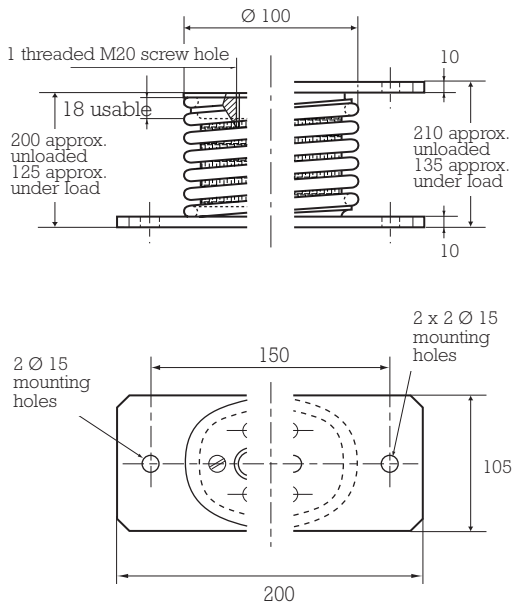

- Maximum permitted excitation at natural frequency of suspension: ± 3 mm.
- Natural frequencies for this amplitude:
 - axial } 1.5 to 3.5 Hz depending on load.
 - radial }
- Amplification factor at resonance: < 5 .
- Structural strength corresponds to continuous acceleration of 2 g with maximum load.
- Operating temperature: $- 70^{\circ}\text{C}$ to $+ 300^{\circ}\text{C}$.

With lower mounting plate	With lower and upper mounting plate	Static axial load daN
V1209-01A	V1209-01B	60 - 95
V1209-03A	V1209-03B	95 - 150
V1209-05A	V1209-05B	150 - 230
V1209-07A	V1209-07B	210 - 330
V1209-09A	V1209-09B	300 - 460

1 kg \approx 1 daN

DESCRIPTION

Part of a series of very low frequency isolators working in compression only, giving very efficient isolation for rotating machines running at 250 rpm and above.

APPLICATIONS

Rotating machines, hoppers and sensitive equipment with or without the use of inertia blocks.

OPERATING CHARACTERISTICS

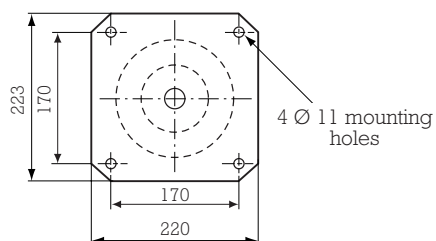
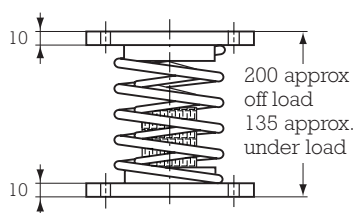

- Maximum permitted excitation at natural frequency of suspension: ± 3 mm.
- Natural frequencies for this amplitude:
 - axial } 1.5 to 3.5 Hz depending on load.
 - radial }
- Amplification factor at resonance: < 5 .
- Structural strength corresponds to continuous acceleration of 2 g with maximum load.
- Operating temperature: $- 70^{\circ}\text{C}$ to $+ 300^{\circ}\text{C}$.

Reference	Static axial load daN
V1210-51	460 - 740
V1210-52	550 - 870
V1210-53	700 - 1100
V1210-54	1000 - 1600
V1210-55	1300 - 1960

1 kg \approx 1 daN

V1B-5984-01 V1B-5984-11

DESCRIPTION

The assembly comprises:

- two metal cushions;
- a threaded centre axis;
- a nut;
- two flat washers;
- two Belleville washers.

APPLICATIONS

Mountings for transformers with a locking system for use in transit.

OPERATING CHARACTERISTICS

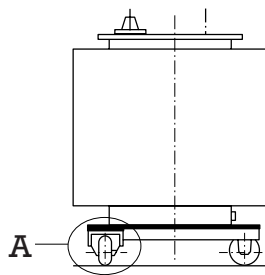

- Natural frequencies:
 - axial } 10 to 15 Hz depending on load.
 - radial }
- Attenuation 100 Hz > 90%.
- Good resistance to oil.
- Electrically conductive.

ENLARGEMENT POINT A

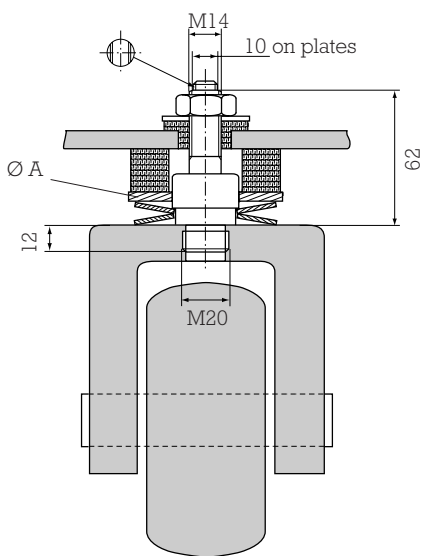

Not supplied

Reference	Static load daN	Locking torque in N.m (for use when transformer in transit)	Ø A mm
V1B-5984-01	930	90	65
V1B-5984-11	1500	100	75

1 kg ≈ 1 daN

Torque when transformer in use for both types = 0 N.m.

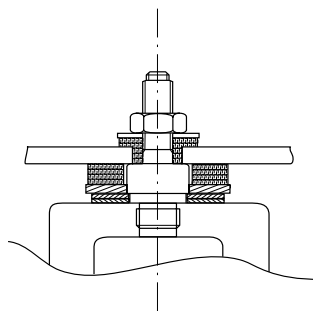

Locked position
during transit

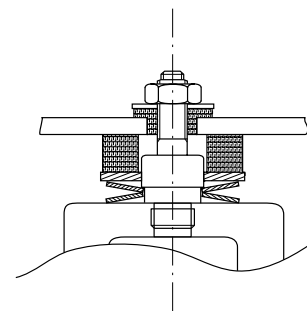

Unlocked position
transformer
in use

NUMERIC INDEX

Reference	Page	Reference	Page	Reference	Page	Reference	Page
000 51 422	30	SP561W	37	V1N305	65	V47Q	35
000 51 423	30	SP562W	37	V1N306	65	V47T	35
000 51 430	30	SP563W	37	V1N308	65		
000 51 431	30	V118-DG	41	V318	41	V402-MG	47
000 51 432	30	V118-MG	41	V318-D	41	V6080 F43	25
000 51 433	30	V120	43	V3CA8010	62-63	V6080 F43W	25
7002	58	V120-D	43	V3CA8020	62-63	V6080 F44	25
				V3CA8030	62-63	V6080 F44W	25
CH264-A02	21	V1209	66	V3CA8040	62-63	V6080 F45	25
CH265-A02	21			V3CA8060	62-63	V6080 F45W	25
CH281-A02	21	V1210	67	V3CA8080	62-63	V6080 F46	25
CH283-A02	21			V3CA8090	62-63	V6080 F46W	25
CH438-A02	21	V125	43	V3CA8100	62-63	V6056K01	30
CH440-A02	21	V125-D	43	V3CA8110	62-63	V6057K01	30
CH472-A02	21			V3CA8120	62-63	V6058K01	30
		V164	45	V3CA8140	62-63		
KT43	32	V168	45			VE101	60
KT44	32			V3CNCH682-A05	21	VE111	60
KT45	32	V1B1114	55			VE112	60
KT46	32	V1B1115	55	V3CNVI034-A06	21	VE113	60
		V1B1116	55				
MC345-A02	21			V3CNVI653-A02	21	VI168-B	21
		V1B1134	55-56				
MV801	63	V1B1135	55-56	V3CNVJ006-A06	21	VI700-A06	21 & 28
MV803	63	V1B1136	55-56			VI700-B06	21 & 28
				V3CNVJ044-A05	21	VI786-A06	21 & 27
PDM-1000-01	36	V1B-5984-01	68	V3CNVJ102-A05	21		
PDM-2000-01	36	V1B-5984-11	68			VI771-B02	21
				V3CNVJ121-A06	30	VI830-B06	21
SP539-882	39	V1H5023	51	V3CNVJ122-A06	30	VI996-A02	21
SP539-883	39	V1H5025	51	V3CNVJ123-A06	30		
						VJ148-A05	21
SP539-887	39	V1H-6000	53	V43	32-33		
SP539-888	39	V1H-6100	53	V44	32-33	VJ149-A06	21
				V45	32-33		
SP550W	37	V1H751	49	V46	32-33	VJ164-A05	21
SP551W	37	V1H752	49				
SP552W	37			V47	35		
SP553W	37	V1N303	65	V47D	35		
SP560W	37	V1N304	65				

OTHER PAULSTRA DOCUMENTATION

Available upon request



**FLEXIBLE
MOUNTINGS**
CATALOG



**FLEXIBLE
COUPLINGS**
CATALOG



**FLEXIBLE
BUSHES**
CATALOG

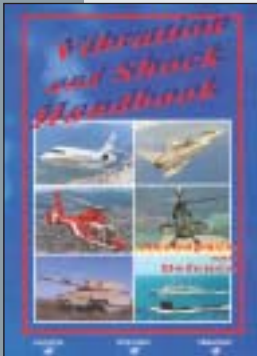

**AEROSPACE
AND DEFENCE**
CATALOG

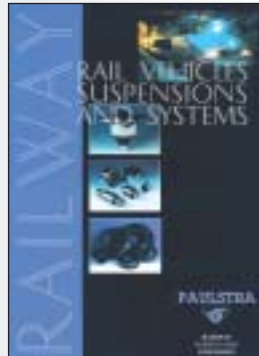

RAILWAY
CATALOG

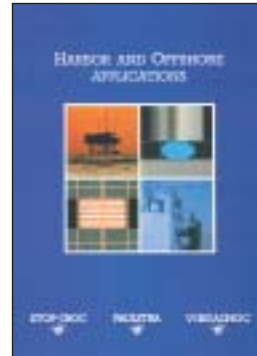

OFFSHORE
CATALOG

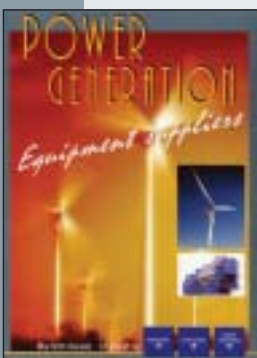

**POWER
GENERATION**
LEAFLET

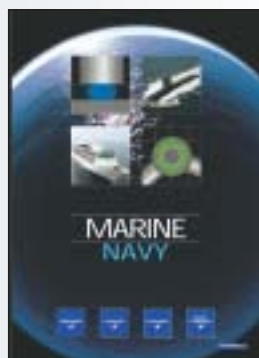

MARINE / NAVY
LEAFLET



**INDUSTRIAL
VEHICLES**
LEAFLET